

Single Point Load Cell



FEATURES

- Capacities: 6 - 60kg
- Fully welded, stainless steel construction
- Hermetically sealed, IP66 and IP68
- Certified to OIML R-60, 3000d
- Comprehensive mounting hole facility
- Moment insensitive, platform size to 350 x 350mm

OPTIONAL FEATURE

- ATEX and FM certified versions are available for use in potentially explosive atmospheres

DESCRIPTION

The HPS is a unique fully welded all stainless steel single point (moment insensitive) load cell.

This product is suitable for low capacity platform scales, multi-head packaging machines, check weighers, loss-in-weight feeders, belt scales and general process weighing applications.

The unique construction ensures that this product can be used successfully in harsh environments found in the food, chemical and allied industries.

This product meets the stringent Weights and Measures requirements throughout Europe.

APPLICATIONS

- Food platforms
- Process weighing
- Multi-head packaging machines
- Marine hybrid scales

OUTLINE DIMENSIONS in millimeters

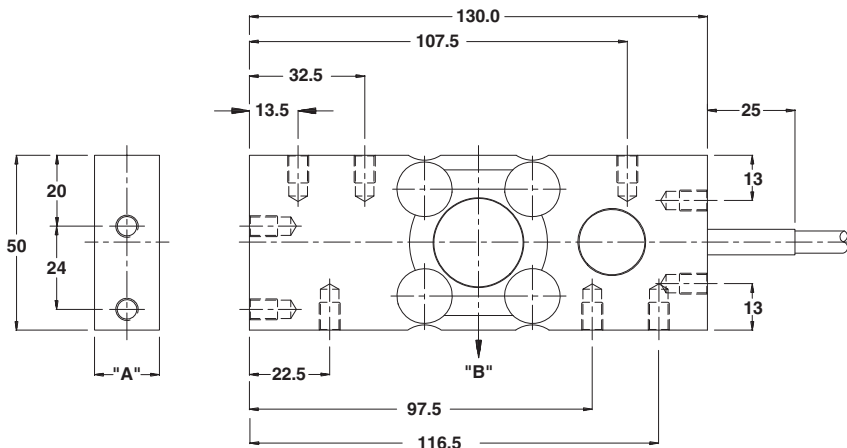

Cable specifications:

- Cable length: 7m
- Excitation + Green
 - Excitation - Black
 - Output + White
 - Output - Red
 - Sense + Yellow
 - Sense - Blue
 - Shield Transparent
- Cable screen is not connected to load cell body.

Capacity (kg)	6, 12, 30	60
A	18.5	23.5
B	Central load axis	
Max. recommended platform size 350mm		
All threads M6x1 (8 Deep)		

**SPECIFICATIONS**

PARAMETER	VALUE		UNIT
Standard capacities (E_{max})	6, 12, 30, 60		kg
Accuracy class according to OIML R-60	Non-Approved	C3	
Max. no. of verification intervals	3000		
Min. verification interval (V_{min})	$E_{max}/12000$		
Rated output (=S)	2		mV/V
Rated output tolerance	0.2		±mV/V
Zero balance	1.0		±% FSO
Combined error	0.0500	0.0200	±% FSO
Non-repeatability	0.0200	0.0100	±% FSO
Minimum dead load output return	0.0500	0.0167	±% applied load
Creep error (30 minutes)	0.0600	0.0245	±% applied load
Temperature effect on min. dead load output	0.0250	0.0058	±% FSO/5°C (°F)
Temperature effect on sensitivity	0.0250	0.0045	±% applied load/5°C (°F)
Eccentric load effect*	0.03		±% FSO
Minimum dead load	0		% E_{max}
Maximum safe over load	150		% E_{max}
Ultimate over load	300		% E_{max}
Maximum safe side load	100		% E_{max}
Deflection at E_{max}	0.24±0.02/ 0.19±0.01/ 0.15±0.01/ 0.22±0.03		mm
Excitation voltage	5 to 12		V
Maximum excitation voltage	15		V
Input resistance	400±6	410±6	Ω
Output resistance	350±7		Ω
Insulation resistance	≥5000		MΩ
Compensated temperature range	-10 to +40		°C
Operating temperature range	-40 to +80		°C
Storage temperature range	-40 to +90		°C
Element material (DIN)	Stainless steel 1.4542		
Sealing (DIN 40.050 / EN60.529)	IP66 and IP68		
Recommended torque on fixation bolts	6		N*m

* Applies at 50% x Rated Load at 150mm radius

VISHAY TRANSDUCERS (VT) SALES OFFICES

VT Americas
City of Industry, CA
PH: +1-626-858-8899
FAX: +1-626-332-3418
vt.us@vishaymg.com

VT Netherlands
Breda
PH: +31-76-548-0700
FAX: +31-76-541-2854
vt.nl@vishaymg.com

VMG UK
Basingstoke
PH: +44-125-646-2131
FAX: +44-125-647-1441
vt.uk@vishaymg.com

VMG Israel
Netanya
PH: +972-9-863-8888
FAX: +972-9-863-8800
vt.il@vishaymg.com

VMG Germany
Heilbronn
PH: +49-7131-3901-260
FAX: +49-7131-3901-2666
vt.de@vishaymg.com

VT China
Tianjin
PH: +86-22-2835-3503
FAX: +86-22-2835-7261
vt.prc@vishaymg.com

VMG France
Chartres
PH: +33-2-37-33-31-20
FAX: +33-2-37-33-31-29
vt.fr@vishaymg.com

VT Taiwan*
Taipei
PH: +886-2-2696-0168
FAX: +886-2-2696-4965
vt.roc@vishaymg.com
*Asia except China