

Digital Self Contained Weighing Module

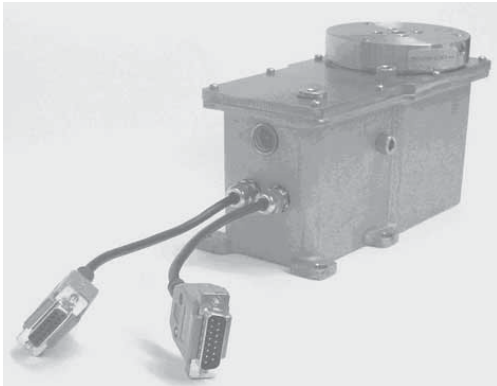

FEATURES

- Capacities 3-50kg
- Unique adjustable tare load cancelling mechanism
- Highly effective viscous damping
- 6 Built-in overload limit stops in three directions
- IP65 protection
- Fully calibrated filtered digital output
- High update rate, up to 1200 updates per second
- 4 opto-isolated digital inputs
- 4 opto-isolated digital outputs
- Advance configurable digital filtering
- Safeguard access to calibration data for approved applications
- Reading on request or continuous output
- Extensive diagnostics

OPTIONAL FEATURES

- Stainless steel
- IP66 with additional breather tube

DESCRIPTION

Model 9010 is a self contained weighing module for use in repeated shock-loading applications or where fast weighing and settling times are required such as multihead weighers, check weighers and other static and dynamic weighing applications characterized by sudden or impact loading.

Model 9010D's unique fluid damping system allows the load cell to be used in applications that previously required the use of LVDT's or similar types of measuring devices.

The model 9010D has a unique adjustable tare load cancellation feature which brings load cell adaptability into checkweighing and grading applications.

On board electronics make it highly configurable and simple to employ in dynamic weighing applications. A great proportion of the functionality required to create a fully featured weighing system is already implemented in the 9010D.

Communication is straightforward using an ASCII or MODBUS command structure and high update speeds are possible, making it particularly suitable for check weighing. Up to 128 units can be networked together over an RS485 link.

4 digital inputs allow the synchronization of the weighing with external triggers and remote operations (zero, tare). 4 digital outputs enable control functions like coarse and fine rate filling, and relieve the real-time load of the system controller.

Factory calibration ensures that each unit will be virtually identical in performance.

Graphic User Interface (GUI) PC application enables easy monitoring, setup and calibration of all load cells connected on the RS485 network. Load cell parameters can be retrieved and stored for backup, and downloaded into the load cell for easy recovery from failures or changing operating modes.

OUTLINE DIMENSIONS in millimeters

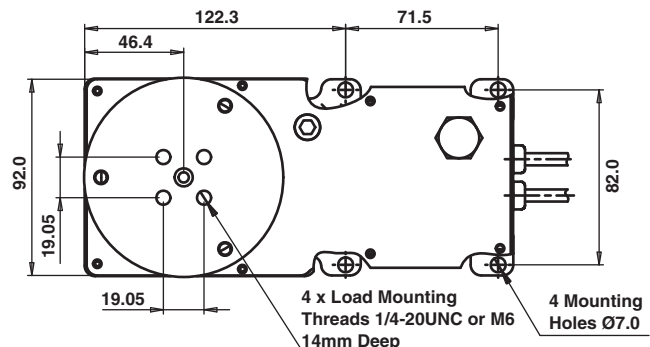
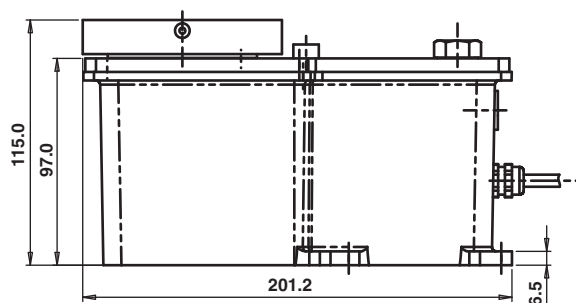

COMMUNICATING WITH THE 9010D

A typical digital weighing installation will consist of a host device (e.g. PC, digital indicator, PLC) and between 1 to 128 load cells connected over a single RS485 bus via a single cable. Over this connection commands are issued by the host and the load cells respond with readings and status information. Both RS232 and RS485 interfaces are available in parallel and the user can select either ASCII or MODBUS protocol.

DIAGNOSTICS

A significant advantage of the digital load cell is in terms of cost of ownership. The analogue load cell, especially in multi-cell applications can be awkward to set up and to isolate faults. In a production line environment, the real cost of determining and resolving equipment problems is high. Reliable and meaningful feedback about load cell operation and fault conditions are essential for fast recovery and this is where the Digital 9010 pays for itself.

The 9010D has a number of key features in terms of diagnostics of the cell operation:

1. External indication of errors - a bi-color LED is used to show status and fault conditions. Even in the worst case, if communication with the load cell is not possible, the 9010D can still give an indication of its conditions and set up.
2. Internal error log - a time referenced log of errors is maintained which allows tracing of repeating fault conditions, and identification of time of serious fault (e.g. overload / underload).
3. Validity of readings - with each reading, status characters are transmitted. Fatal errors cause readings to cease and error codes are transmitted.
4. Integrity of calibration - at power up the cell(s) self check to assure:
 - (a) Calibration
 - (b) Hardware, software and system integrity

HIGH PERFORMANCE DYNAMIC WEIGHING

Weigh Module 9010 consists of a Vishay Tedea-Huntleigh single point load cell enclosed in an environmentally protected, electroless nickel plated aluminium housing. The Module integrates load cell performance, viscous damping, adjustable tare offset mechanism and overload protection.

LOAD CELL

Vishay Tedea-Huntleigh's Model 1010, 1040 or 1140 single point load cells can be used in the Model 9010. Standard capacities 3kg to 50kg; for higher capacities, consult Vishay Tedea-Huntleigh.

OVERLOAD PROTECTION

Model 9010 is equipped with built-in overload stops for positive (push), negative (pull) and twisting loads. These stops are factory adjusted for each specific application according to customer definitions.

DAMPING

Model 9010 features a unique viscous damping technique developed and patented by Vishay Tedea-Huntleigh, which provides

- Faster settling time
- Higher weighing speeds
- Load cell protection (extended working life)

Damping parameters are factory set for each specific application.

TARE LOAD CANCELLING

Model 9010 features an adjustable tare load cancelling mechanism which provides a tare offset of up to 35kg (in several ranges). The tare offset is factory set but may be adjusted by the user. This feature enables the use of a lower capacity load cell, resulting in electronic circuits with lower gains, lower noise, higher stability and lower temperature drifts.

An example for the power of tare cancelling:
Assume an application with 5kg dead load and 2kg (useful) load.

1. Without tare cancelling:
Total load of 5+2 is 7kg, therefore, a load cell with capacity of at least 10kg has to be selected.
2. With tare cancelling:
The 5kg dead load can be opposed and effectively cancelled by the Tare Cancellation Mechanism, leaving a load of 2kg only, hence a capacity of 3kg can be selected.
3. Results:
A capacity of 3kg rather than of 10kg is enabled by the Tare Cancellation feature for a gain of over 3 times in resolution and noise.

LOAD CELL DURABILITY

Because of the design and unique features of Model 9010, the durability of the load cell is increased substantially. For example, in one typical set of durability tests, the undamped load cell failed after approximately 300,000 cycles. The damped load cell held without any significant deterioration for more than 300 million cycles. In this test a model 1010-10kg load cell was used. A dead load of 2.5kg was mounted 150mm from the mounting centre. A 4.5kg impact was applied at that point at a rate of 8 times/sec.

ENVIRONMENTAL PROTECTION

The load cell in the model 9010 is completely enclosed in a rugged, electroless nickel plated aluminium or stainless steel housing to withstand splashing. It is environmentally protected to IP65, a special "breather valve" allows atmospheric pressure equalization while excluding splashing liquids.

With an optional addition of a breather tube the protection is rendered IP66. A built-in shut-off valve is used for shipping.

SETTLING TIME

Settling time is the elapsed time from the instant of loading to the time the load cell's signal remains within the user specified accuracy.

Settling time is affected by the following parameters.

1. Total mass on the module and it's distance from the mounting centre.
2. Impact loading characteristics.
3. Environmental temperature change.

For optimum performance, the above parameters must be specified by the user for each order.



SPECIFICATIONS

PARAMETER	VALUE	UNIT
Rated capacity (R.C.)	3, 5, 7, 10, 15, 20, 30, 50	kg
VT Accuracy class	G	
Maximum no. of intervals (n)	3000	
Total error*	0.030	±% of R.O.
Temperature effect on span*	0.002	±% of R.O./°C
Temperature effect on zero: load cell	0.004	±% of load/°C
buoyancy	0.15	+g/°C rise
tare offset	0.25 X tare offset (kg)	+g/°C rise
Temperature range - standard*	10 to 30	°C
Tare offset ranges	0 to 35	kg
Safe static overload downward at mounting centre	800	% of R.C.
upward at mounting center	400	% of R.C.
200mm in front or side of mounting center	200	% of R.C.
Setting time - typical	40 - 300	ms
Temperature effect on setting time	2	%/°C
Power supply	6 - 30	VDC
Weight	3	kg
Construction	Anodized body, electroless plating**	
Environmental protection	IP65	
ELECTRICAL SPECIFICATIONS		
Input voltage.	6 to 30	VDC
Current consumption	<100	mA
External resolution	1,000,000	Counts
Update rate	18.75, 37.5, 75, 150, 300, 600 and 1200	Readings/sec
Digital filtering	FIR, recursive or user defined	
Digital filter cut-off frequencies	FIR: 2.5, 5, 10, 20, 40, 80, and 150 Recursive: 0.25, 0.5, 1, 2, 5, 10, 20, and 38	Hz Hz
Calibration method	Dead load, mV/V or table	
Digital inputs	4, with common return	
Type	TTL or dry contact	
Settling time	<20	ms
Digital outputs	4	
Type	Open collector with common emitter	
Settling time	<20	ms
COMMUNICATION SPECIFICATIONS		
Interface	RS232, RS485	
Protocol	ASCII, Modbus	
Communication Speed	2400, 4800, 9600, 19200, 38400, 57600, 115200, 230400	Baud
Data Bits	7 or 8	Bits
Stop Bits	1 or 2	Bits
Parity	Odd/even/none	
RS485 bus termination	Internal, activated by software command	

* Extended temperature ranges and smaller temperature effects are available upon request.

** Optional stainless steel coating available upon request.

*** IP66 available with additional breather tube.

APPLICATION AND ORDER DATA

TO BE COMPLETED BY THE CUSTOMER

CUSTOMER'S NAME ORDER No.

CONTACT PERSON DATE

APPLICATION No. of UNITS

TOTAL TARE WEIGHT (DEAD LOAD).....kg; FOR EACH UNIT..... kg

TOTAL USEFUL WEIGHT (LIVE LOAD)kg; FOR EACH UNIT..... kg

DESCRIBE LIVE LOAD (POWDER, FRUIT, SCREWS ETC)

REQUIRED SETTLING TIMEmsec; ACCURACY.....

OPERATING TEMPERATURE RANGE °C:

MOUANTING THREADSmm (6x1) inch (1/4 UNC)

PREFERRED LOAD CELL, IF ANY

1. CHECKWEIGHER (SEE SKETCH BELOW):

SIZE OF CONVEYOR PLATFORM:

WIDTH..... cm; A cm; Bcm; C cm

SPEED OF BELT cm/sec; SIZE OF WEIGHED PRODUCT IN MOVEMENT DIRECTION..... cm

TARE WEIGHT DISTRIBUTION: CONVEYOR: kg; MOTOR:..... kg

2. HOPPER OR OTHER APPLICATION (SEE SKETCH BELOW):

CENTER OF GRAVITY (CofG) OF DEAD LOAD, (ESTIMATE IF NECESSARY): D.....cm; F cm

LOADING POSITION: D cm; F cm; DROP HEIGHT:..... cm

IF LOAD CofG VAIRIES, MAX DIST. BETWEEN EXTREMES cm

SPECIAL REQUIREMENTS

CABLE LENGTH IF NOT STANDARD (1 m) ; DELIVERY REQUESTED

CORNERS ACCURACY: TEST WEIGHT (MAX. ALLOWED 1/3 OF LOAD CELL CAPACITY)..... kg

DISTANCE FROM CENTERcm VARIATION ALLOWED

DEFINITION OF LOADING POSITION RELATIVE TO 9010

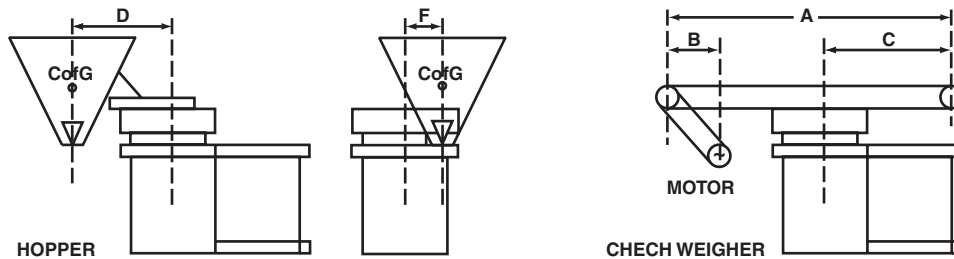

VISHAY TRANSDUCERS (VT) SALES OFFICES

VT Americas
 City of Industry, CA
 PH: +1-626-858-8899
 FAX: +1-626-332-3418
 vt.us@vishaymg.com

VT Netherlands
 Breda
 PH: +31-76-548-0700
 FAX: +31-76-541-2854
 vt.nl@vishaymg.com

VMG UK
 Basingstoke
 PH: +44-125-646-2131
 FAX: +44-125-647-1441
 vt.uk@vishaymg.com

VMG Israel
 Netanya
 PH: +972-9-863-8888
 FAX: +972-9-863-8800
 vt.il@vishaymg.com

VMG Germany
 Heilbronn
 PH: +49-7131-3901-260
 FAX: +49-7131-3901-2666
 vt.de@vishaymg.com

VT China
 Tianjin
 PH: +86-22-2835-3503
 FAX: +86-22-2835-7261
 vt.prc@vishaymg.com

VMG France
 Chartres
 PH: +33-2-37-33-31-20
 FAX: +33-2-37-33-31-29
 vt.fr@vishaymg.com

VT Taiwan*
 Taipei
 PH: +886-2-2696-0168
 FAX: +886-2-2696-4965
 vt.roc@vishaymg.com
 *Asia except China