

Load Cell for Rotary Filling Machines



FEATURES

- The first and only load cell specifically designed for use in rotary filling machines
- Short settling times
- High resistance to side loads
- Effective isolation of base vibrations
- Centrifugal forces do not affect accuracy
- Two mounting options

DESCRIPTION

Model 1410 represents a radical new concept in load cell design, which alleviates many of the problems encountered when conventional load cells are used in rotary weighing machines.

Due to a patented damping system, typical settling times of 700ms are dramatically reduced to less than 300ms (depending upon conditions), significantly reducing cycle times and increasing throughput capabilities.

Centrifugal forces are handled in such a way that their effect on output is very small.

For example, tested up to 20 RPM, total dynamic error amounted to less than 0.2 gram per kg. Also the model 1410 provides excellent isolation of base vibrations. Both features enable use of higher machine speeds without loss of accuracy.

The uniquely rugged construction of the model 1410 is very resistant to side loads and can therefore withstand bottle jams and other mishaps.

APPLICATIONS

- Rotary filling machines

OUTLINE DIMENSIONS in millimeters

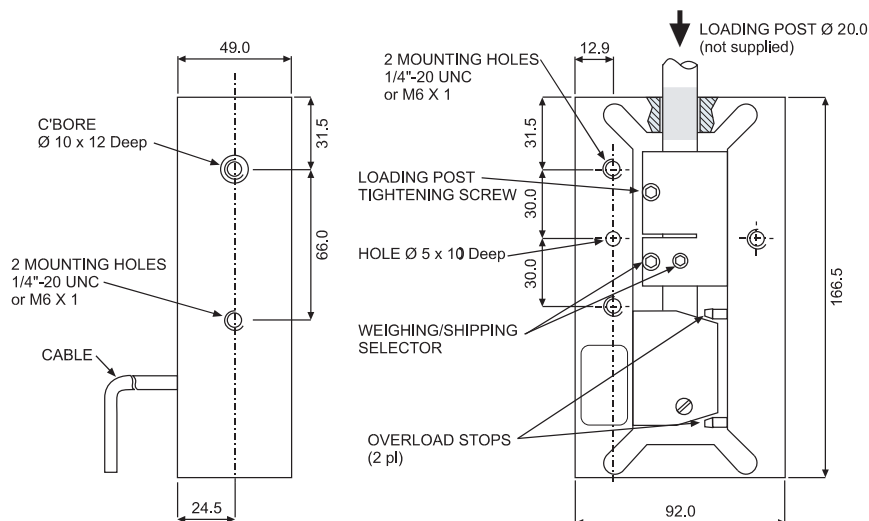

For different mounting configuration consult factory.

**SPECIFICATIONS**

PARAMETER	VALUE		UNIT
Rated capacity-R.C. (E_{max})	10, 20, 30		kg
T-H Accuracy class	E	G	
Rated output-R.O.	2		mV/V
Rated output tolerance	0.3		±mV/V
Zero balance	-0.0 / +0.2		±mV/V
Total static error at room temperature per OIML	0.05	0.02	±% of R.O.
Dynamic error: speed range of 0 to 15rpm, rotational radius of 1m, load placed on platform located 14cm above top surface of load-cell & connected by 3/4" or 20mm dia. steel shaft	0.04		±% of the static reading at same load
Creep & Zero return (30 min.)	0.05	0.025	±% of load
Temperature effect on zero	0.010	0.004	±% of R.O./°C
Temperature effect on output	0.003	0.001	±% of load/°C
Temperature range, compensated	+5 to +40		°C
Temperature range, safe	-30 to +70		°C
Maximum safe static overload, positive	160 Factory adjusted to 120 ... 160% of R.C.		% of R.C.
Maximum safe static overload, negative	-120 Factory adjusted to -30 ... -120% of R.C.		% of R.C.
Ultimate static overload (central loading)	300		% of R.C.
Excitation, recommended	10		Vdc or Vac rms
Excitation, maximum	15		Vdc or Vac rms
Input impedance	415±15		Ohms
Output impedance	350±3		Ohms
Insulation resistance	>2000		Mega-Ohms
Cable length	0.6		m
Construction	Anodized aluminum		
Damping	Internal silicone fluid damping. Piston has two positions: Working and shipping. In shipping position the cylinder is sealed		

Wiring Schematic Diagram
(unbalanced bridge configuration)

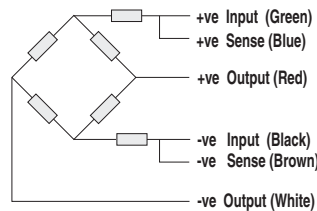
**VISHAY TRANSDUCERS (VT) SALES OFFICES**

VT Americas
City of Industry, CA
PH: +1-626-858-8899
FAX: +1-626-332-3418
vt.us@vishaymg.com

VT Netherlands
Breda
PH: +31-76-548-0700
FAX: +31-76-541-2854
vt.nl@vishaymg.com

VMG UK
Basingstoke
PH: +44-125-646-2131
FAX: +44-125-647-1441
vt.uk@vishaymg.com

VMG Israel
Netanya
PH: +972-9-863-8888
FAX: +972-9-863-8800
vt.il@vishaymg.com

VMG Germany
Heilbronn
PH: +49-7131-3901-260
FAX: +49-7131-3901-2666
vt.de@vishaymg.com

VT China
Tianjin
PH: +86-22-2835-3503
FAX: +86-22-2835-7261
vt.prc@vishaymg.com

VMG France
Chartres
PH: +33-2-37-33-31-20
FAX: +33-2-37-33-31-29
vt.fr@vishaymg.com

VT Taiwan*
Taipei
PH: +886-2-2696-0168
FAX: +886-2-2696-4965
vt.roc@vishaymg.com
*Asia except China