

PW15AH...

Single point load cell

Special features

- Nominal load 10 kg ... 100 kg
- Stainless steel
- High ratio of minimum verification interval Y
- Industrial Footprint (SP4M)
- Degree of Protection IP68; IP69K
- Different cable lengths and other options available



Dimensions (in mm; 1 mm= 0.03937 inches)

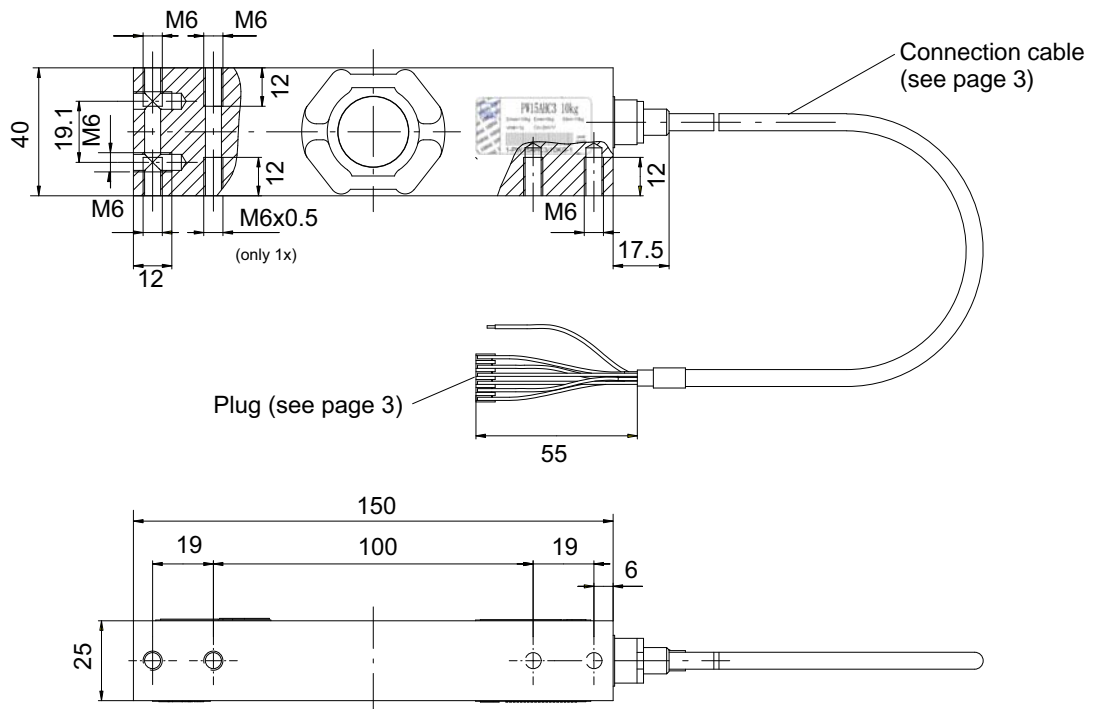

Specifications

Type			PW15AH/PW15AHY (C3 MR)			
Accuracy class ¹⁾			C3 Multi Range (MR)			
Max. number of load cell interval	n_{LC}		3000			
Maximum capacity	E_{max}	kg	10	20	50	100
Min. LC verification interval	v_{min}	g	1	2	5	10
Ratio of minimum verification interval (PW15AH)	Y		10000			
Temperature effect on zero balance (PW15AH)	TK_0	% of $C_n / 10\text{ K}$	± 0.0140	± 0.0140	± 0.0140	± 0.0140
Ratio of minimum verification interval (PW15AHY)	Y		20000		25000	20000
Temperature effect on zero balance (PW15AHY)	TK_0	% of $C_n / 10\text{ K}$	± 0.0070	± 0.0070	± 0.0056	± 0.0070
Maximum platform size		mm	500 x 400			
Sensitivity	C_n	mV/V	2.0 \pm 0.2			
Zero balance			0 \pm 0.1			
Temperature effect on sensitivity ²⁾ Temperature range: +20 ... +40°C [+68 ... +104°F] -10 ... +20°C [+14 ... +68°F]	TK_C	% of $C_n / 10\text{ K}$	± 0.0175 ± 0.0117			
Hysteresis error ²⁾	d_{hy}	% of C_n	± 0.0166			
Non-linearity ²⁾	d_{lin}		± 0.0166			
Minimum dead load output return	DR		± 0.0166			
Off center load error ³⁾			± 0.0233 ³⁾			
Input resistance	R_{LC}	Ω	300 ... 500			
Output resistance	R_0		300 ... 500			
Reference excitation voltage	U_{ref}	V	5			
Nom. range of excitation voltage	B_U		1 ... 12			
Max. excitation voltage			15			
Insulation resistance with 100 V _{DC}	R_{is}	G Ω	> 1			
Nominal temperature range	B_T	°C [°F]	-10 ... +40 [+14 ... +104°F]			
Service temperature range	B_{tu}		-10 ... +50 [+14 ... +122°F]			
Storage temperature range	B_{tl}		-25 ... +70 [-13 ... +158°F]			
Safe load limit ^{*)}	E_L	% of E_{max}	150			
^{*)} at max. eccentricity		mm	160			
Lateral load limit, static	E_{lq}	% of E_{max}	300			
Breaking load	E_d		300			
Deflect. at E_{max} , approx.	s_{nom}	mm	< 0.5			
Weight, approx.	m	kg	1.0			
Protection class ⁵⁾			IP 68 (test conditions 100 h at 1 m water column); IP69K (water at high pressure, steam jet cleaning) ⁴⁾			
Material	Measuring element Cable sheath		1.4545 ⁶⁾ PVC			

1) According to OIML R60 with $P_{LC} = 0.7$

2) The data for Non-linearity (d_{lin}), Hysteresis error (d_{hy}) and Temperature effect on sensitivity (TK_C) are typical values. The sum of these data meets the requirements according to OIML R60.

3) According to OIML R76

4) Following the definitions of the DIN 40050, part of 9, for road vehicles

5) According to EN60529 (IEC529)

6) According to EN 10088-1

Wiring code

Connection with 6 wire cable (selectable cable length: 3 m; 6 m)

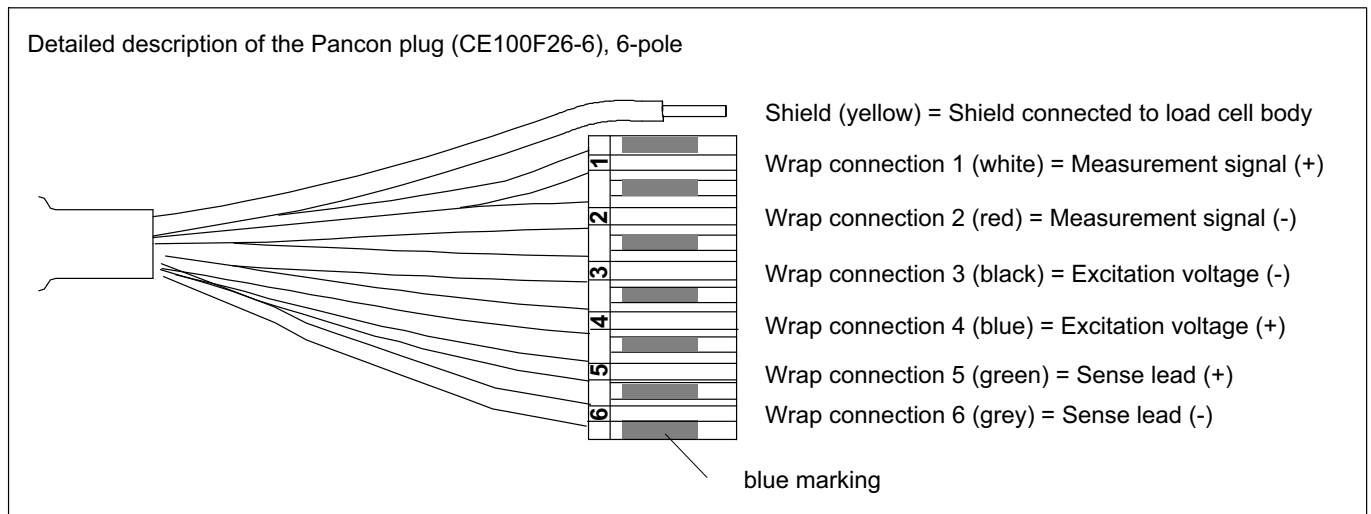

Cable protection (to be implemented by the customer)

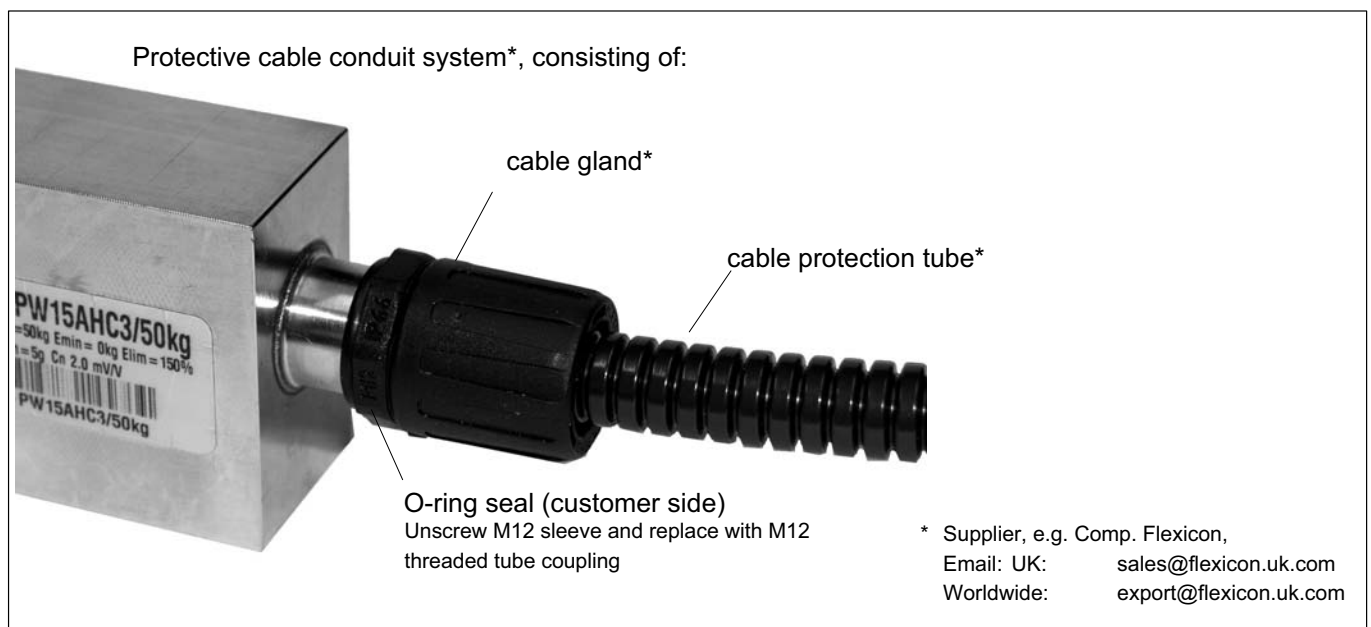

Load application

Load must not be applied to the side where the cable connection is located, as this would cause a force shunt.

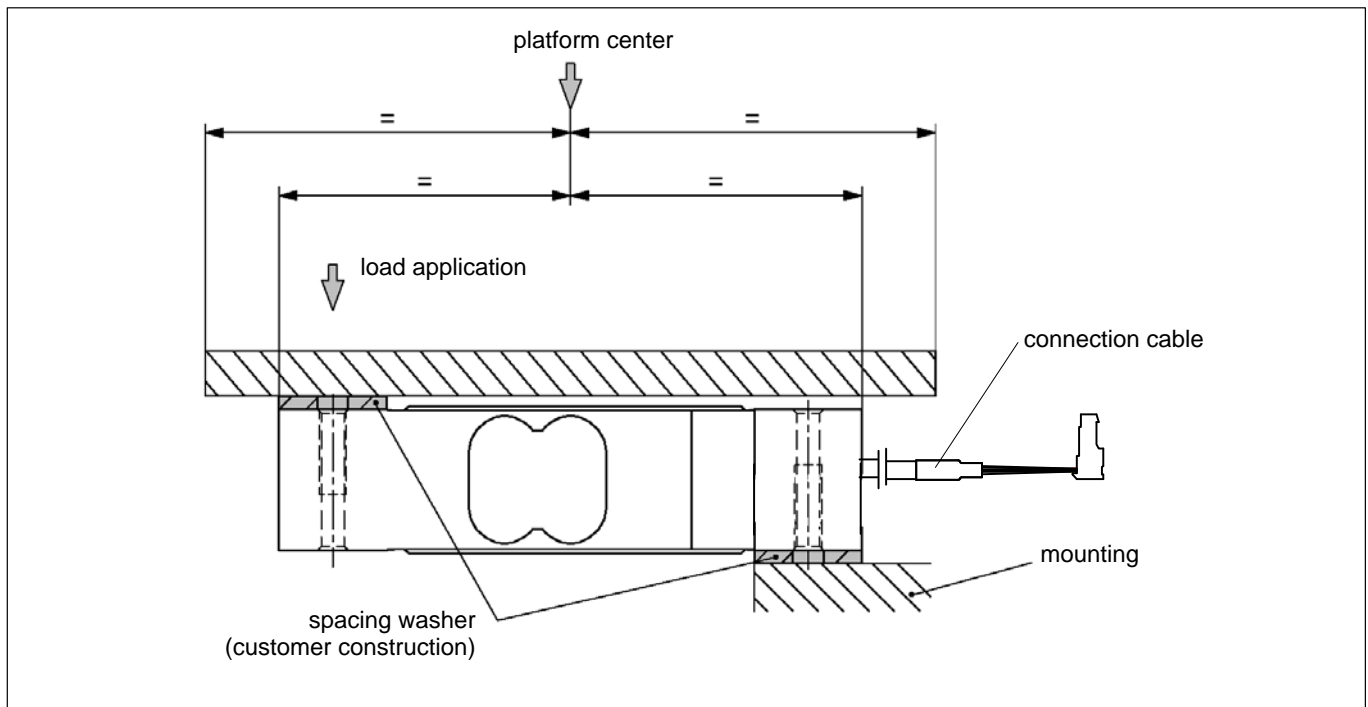

Ordering codes

PW15AH... (Stainless steel, hermetically sealed)

Type	PW15AH	PW15AHY
Accuracy class	C3-MR (OIML) (Multi Range)	C3-MR (OIML)
Comments	Cable length 3 m (6-wire)-	
Capacity	Order number	
10 kg	1-PW15AHC3/10KG-1	1-PW15AHY/10KG-1
20 kg	1-PW15AHC3/20KG-1	1-PW15AHY/20KG-1
50 kg	1-PW15AHC3/50KG-1	1-PW15AHY/50KG-1
100 kg	1-PW15AHC3/100KG-1	

PW15AH... (Stainless steel, hermetically sealed), optional versions

Order no.

K-PW15AH

Code	Option 1: Mechanical version
N	Standard

Code	Option 2: Accuracy
MR	C3-MR (OIML)

Code	Option 3: Capacity
10	10 kg
20	20 kg
50	50 kg
100	100 kg

Code	Option 4: Explosion protection
N	No explosion protection
A11/21	IECEX+ATEX Zone 1/21+FM, intrinsically safe II2G Ex ia IIC T6/T4 Gb/II2G Ex ia IIIC T125°C Db
A12/22	IECEX+ATEX Zone 2/22, not intrinsically safe II3G Ex nA IIC T6/T4 Gc/II3D Ex tc IIIC T125°C Dc

Code	Option 5: Cable length
3	3 m
6	6 m

Code	Option 6: Miscellaneous
N	without
A	2mV/V ±0.1% / 359 Ohm ±0.3 Ohm (aligned output, suitable for connection in parallel)

Code	Option 7
N	Standard

K-PW15AH - **N** - **M** **R** - - - - -

Subject to modifications.
All product descriptions are for general information
only. They are not to be understood as a guarantee
of quality or durability.

Hottinger Baldwin Messtechnik GmbH
Im Tiefen See 45 · 64293 Darmstadt · Germany
Tel. +49 6151 803-0 · Fax +49 6151 803-9100
Email: info@hbm.com · www.hbm.com

measure and predict with confidence

