



CW-80 CHECKWEIGHER

Standard Features:

- Choice of operating voltage: 115 or 230 VAC, 50 or 60 Hz
- Large, bold 0.8" 7-segment, 6 digit, high intensity red LED rapid-response display
- Industrial-quality 304 stainless steel construction
- Rugged 5-point overload protection on platform bases
- **LifeGuard™** shock-absorbing bases on 6 lb to 100 lb capacities in base sizes up to 12" x 12"
- Highly-durable and corrosion-resistant stainless steel load cell on 6 lb to 60 lb capacities with 500% overload protection
- Field-proven aluminum load cell on 100 lb to 1000 lb capacities with 300% overload protection
- NEMA 4X/IP66 indicator enclosure
- **Tough-Touch™** industrial touch-control front panel with keys for over, under, tare, zero, units, print, target and ID
- Displays units in decimal lb, kg, oz, lb & oz, grams
- Annunciator lights for unit selection, net, motion, center of zero, neg
- Storage for up to 300 tare and tolerance settings
- Automatic zero tracking
- Bidirectional RS-232 or simplex 20 mA current loop communication

Options:

Electronics:

- 6 VDC battery pack (4 – 6 hours with full charge)

Outputs:

- 3 TTL level setpoints
- 3 normally-open relays
- 3 normally-closed relays

Software:

- RS-485 communication

Hardware:

- 24" indicator column
- 30" indicator column
- Combination desk/wall mount bracket
- 10" x 10" cutting board
- 12" x 12" cutting board
- 304 stainless steel clamshell load cell protection for capacities of 100 lb and over
- Hermetically-sealed load cells for heavy washdown applications (Consult factory for pricing)

Dimensions:

Platform Dimensions	Standard Column Height
CW-80 6lb, 10lb, 15lb, 30lb 10"L x 10"W x 3"H (254.0mm x 254.0mm x 76.2mm)	12"H (304.8mm)
CW-80 30lb, 60lb, 100lb 12"L x 12"W x 3"H (304.8mm x 304.8mm x 76.2mm)	12"H (304.8mm)
CW-80 100lb, 200lb, 300lb, 500lb, 1000lb 18"L x 18"W x 5.25"H (457.2mm x 457.2mm x 133.3mm)	18"H (457.2mm)
CW-80 200lb, 300lb, 500lb, 1000lb 24"L x 18"W x 5.25"H (609.6mm x 457.2mm x 133.3mm)	18"H (457.2mm)
CW-80 200lb, 300lb, 500lb, 1000lb 24"L x 24"W x 5.25"H (609.6mm x 609.6mm x 133.3mm)	18"H (457.2mm)

Specifications:

INDICATOR

Internal Resolution: 50,000 to 1,000,000 based on filtering selection
Measurement Rate: 25 updates/second
Excitation Voltage: 10 ± .05 VDC, 4 x 350 load cell
Operating Temperature: 14° to 104°F (-10° to 40°C)
Dimensions: 9.5"W x 8.5"H x 3.25"D (241mm x 216mm x 83mm)
Approvals: NTEP certified per H-44: Indicator, 10,000 divisions, Class III/IIIL, CC# 96-118. Base, 3,000 divisions, Class III, CC# 96-107. UL/C-UL listed. OIML EC Type approved certificate #D97-09-033. Canadian Weights and Measures approved: Indicator, AM-5146; Base, AM-5156. CE mark declaration of conformity 2-year limited warranty

Warranty:

Capacities:

CW-80 6lb 6 x .002lb / 96 x .05oz / 3 x .001kg / 3,000 x 1g
CW-80 10lb 10 x .005lb / 160 x .1oz / 5 x .002kg / 5,000 x 2g
CW-80 15lb 15 x .005lb / 240 x .1oz / 7 x .002kg / 7,500 x 5g
CW-80 30lb 30 x .01lb / 480 x .2oz / 15 x .005kg / 15,000 x 5g
CW-80 60lb 60 x .02lb / 960 x .5oz / 30 x .01kg / 30,000 x 10g
CW-80 100lb 100 x .02lb / 1,600 x .5oz / 50 x .01kg / 50,000 x 10g
CW-80 200lb 200 x .05lb / 3,200 x 1oz / 100 x .02kg / 100,000 x 20g
CW-80 300lb 300 x .1lb / 4,800 x 1oz / 150 x .05kg / 150,000 x 50g
CW-80 500lb 500 x .1lb / 8,000 x 2oz / 250 x .05kg / 250,000 x 50g
CW-80 1000lb 1000 x .2lb / 16,000 x 5oz / 500 x 0.1kg / 500,000 x 100g



CW-80 CHECKWEIGHER



Regional Distributor

803, Riqqa Palace Building, Al-Maktum Ave. P.O.Box 181802 Dubai, UAE
 Tel.: +97 14 2270081 Fax: +97 14 2239962 rscsco@eim.ae www.rcs-co.com



RICE LAKE™
 WEIGHING SYSTEMS
 Commitment Beyond Measurement®

www.ricelake.com

SURVIVOR®

One button, no training

With the CW-80's operator-friendly software, simply place your product or target weight on the scale, press "target," and you're ready to checkweigh. The bright, oversized LED display and vibrant "Under," "Over" and "Accept" lights provide the operator with necessary information at a glance.

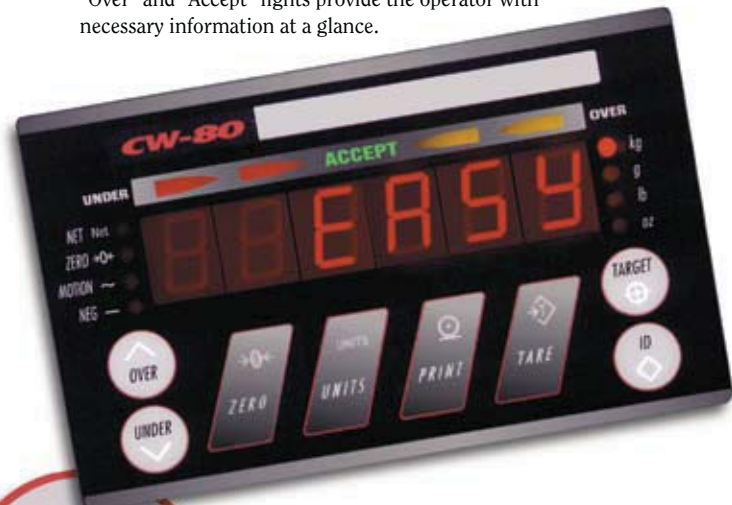

To further simplify operation, the CW-80 allows you to use only the keys you require. If you don't need the additional features, simply turn them off!

The swivel head and optional column heights allow you to create an ergonomically-correct viewing angle for any application. A separate wall-mount bracket is also available for remote indicator mounting up to 10 feet from the base.

Speed is everything

Consistent, high-speed performance is vital to efficient checkweighing operations. The CW-80's advanced signal processor is up to twice as fast as any other checkweigher available, directly increasing production by providing incredible display speed and scale settling time.

Vibration interference eliminated

Operating in a difficult, vibration-filled environment? The CW-80 features our exclusive **RATTLETRAP** Vibration Control. RattleTrap eliminates interference from agitators, mixers, conveyors and other industrial vibration. Now you can depend on fast, stable and accurate weighments regardless of motion on or around your checkweigher.



With the complete range of platform sizes and capacities available, you can handle virtually any size material.

Built to last like no other scale in its class. Four reasons why...

- 1 Advanced new **Tough-Touch™** keypad has an extra-thick polycarbonate cover specially adhered to an all-metal backplate. Washdown-sealed and thru-bolted from inside, it provides unmatched durability and moisture protection, regardless of application.
- 2 True NEMA 4X/IP66 washdown electronics enclosure seals out moisture and contaminants. High-grade 304 stainless steel is used throughout the CW-80's construction.
- 3 Stainless steel IP65 load cell in most popular models for added durability and corrosion resistance.
- 4 Exclusive **LifeGuard™** shock-absorbing base provides exceptional protection against overload and impact forces on platform.



Specially-designed adjustable support pads provide exceptional traction and won't scratch surface.

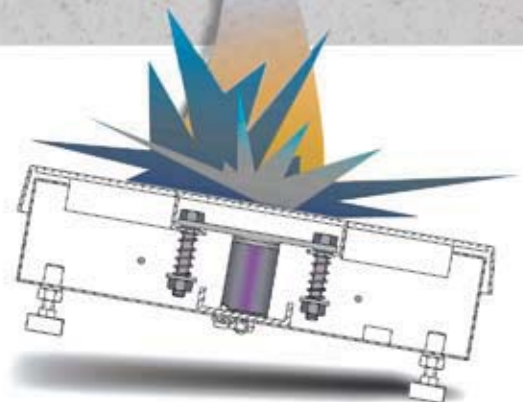

LifeGuard™ overload protection.

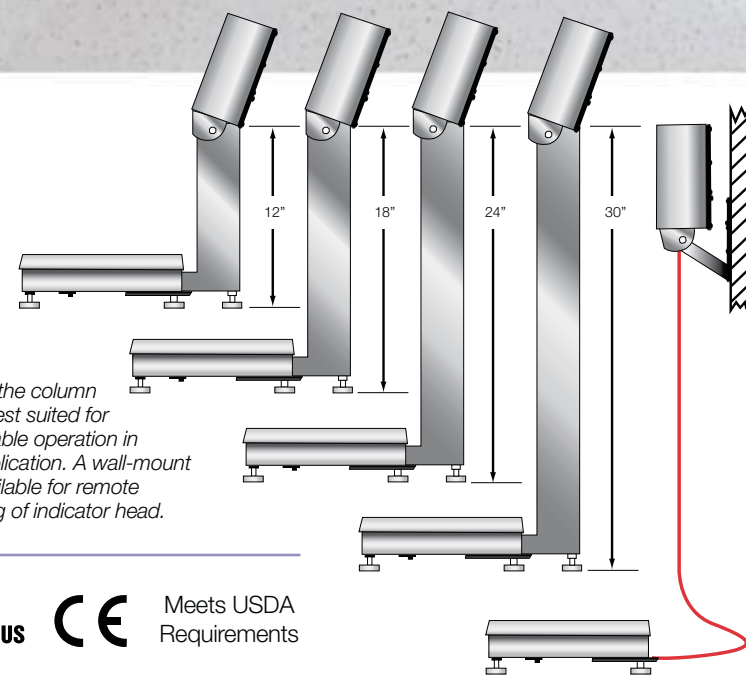

Choose the column height best suited for comfortable operation in your application. A wall-mount kit is available for remote mounting of indicator head.

Expanded capability ready when you need it

When your application requires more than simply a fast, reliable checkweigher, the CW-80 has the power to deliver. Extensive memory storage, advanced communications protocol, setpoint outputs for control functions, and a wide range of power options allow you to tailor the CW-80 for your specific needs.

Memory Storage

With room for up to 300 items, tare and tolerance settings, you can store products by ID# and recall OVER and UNDER tolerances in an instant. No need to stop your process for recalibrations.

If you need to track events over the scale, more than 500 individual weighments can be stored in the CW-80's transaction memory and uploaded to your PC or printed for a hard-copy transaction report.



RS-485
Network up to 32 individually-addressed devices with RS-485 communications.

Advanced Communications

Bidirectional RS-232 or simplex 20 mA current loop is standard on the CW-80. Optional RS-485 communication is also available.

Setpoint Outputs

The three-setpoint option provides control capabilities to support your process needs. Alarms, conveyor motors, feeders and other remote devices can be controlled directly from your CW-80. Outputs are available as: 3 TTL level setpoints, 3 normally-open relays, or 3 normally-closed relays.

Modular design... customize to your application

There's simply no other product available that is this easily customized to your specific needs. When specifying your CW-80, choose a combination of features best suited for your application.

- Wide range of capacities, 6 lb to 1000 lb
- Column heights from 12" to 30"
- Versatile display mounting options—column, tabletop or wall-mount indicator head
- On-scale cutting boards
- RS-485 networking
- Setpoint outputs for control capabilities



Optional high-density white polyethylene cutting board.



CW-80 Indicator
CC# 96-118
n_{max} = 10,000
Class III/IIII

CW-80 Base
CC# 96-107
n_{max} = 3000
Class III

MEASUREMENT CANADA APPROVED
CW-80 Indicator AM-5146 | CW-80 Base AM-5156



Meets USDA Requirements