

BlueLine

Ultra high pressure transducers

Ultra-high pressure transducers to 15,000 bar

Special features

- For static and dynamic pressure variance, pressure peaks and pressure fluctuations
- Principle of measurement: foil strain gage
- Monolithic design, measuring body has no welded seam
- High number of load cycles

Top Class

- Better temperature response
- Individually documented values
- Improved accuracy class
- Closer sensitivity tolerance (suitable for parallel pressure connection, for differential pressure measurement, for example)



P3 Top Class BlueLine



P3MBP BlueLine

Dimensions (in mm)

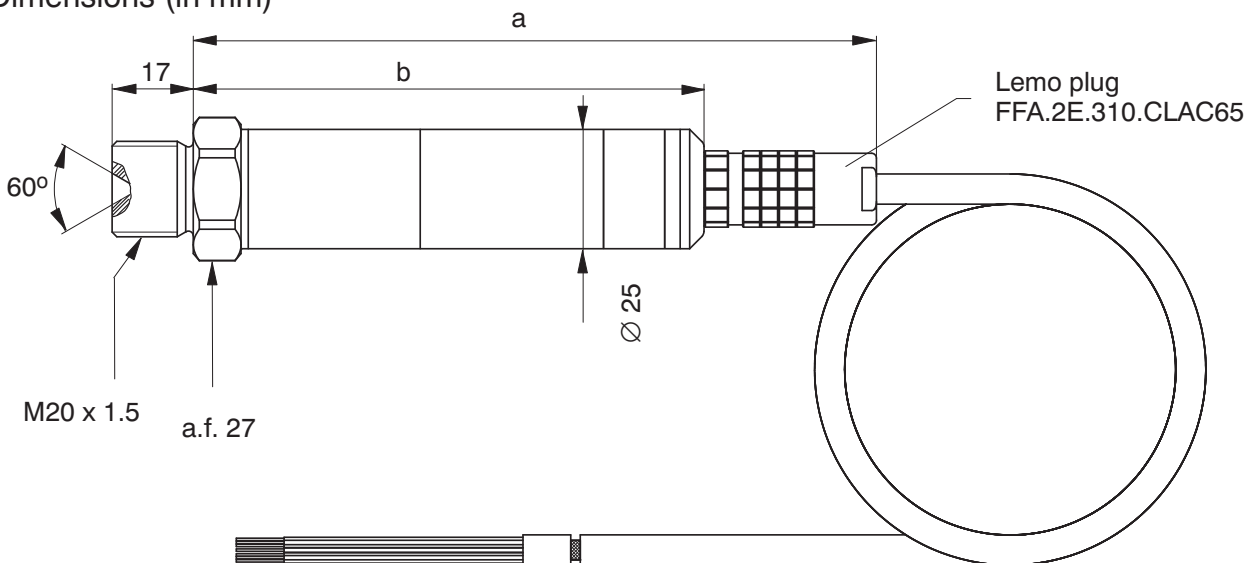

Connection cable 2-9268.0835; 7 m long (not included in scope of supply)

	a	b
P3MBP BlueLine	143	107
P3 Top Class BlueLine	132	96

Specifications P3MBP BlueLine per DIN 16086

Type	P3MBP BlueLine			
Mechanical input quantities				
Pressure type	absolute pressure			
Principle of measurement	foil strain gage			
Measuring range, 0 bar...	bar	5000	10000	15000
Accuracy class ¹⁾		0.3	0.5	0.75
Output characteristics				
Nominal (rated) sensitivity	mV/V	1		
Sensitivity tolerance	%	< ± 0.3	< ± 0.6	< ± 0.8
Effect of temperature on zero signal in the nominal (rated) excitation voltage range per 10K, rel. to nominal (rated) sensitivity				
	in the nominal (rated) temperature range	%	± 0.1	± 0.2
	in the operating temperature range	%	± 0.15	± 0.25
Effect of temperature on sensitivity in the nominal (rated) excitation voltage range per 10K, rel. to actual value				
	in the nominal (rated) temperature range	%	± 0.1	± 0.2
	in the operating temperature range	%	± 0.3	± 0.4
Characteristic curve deviation (start setting)	%	0.3	0.5	0.75
Repeatability per DIN 1319	%	< ± 0.05		

1) Accuracy class is not a DIN 16086 concept. The figure conforms to the maximum single deviation; that is the characteristic curve deviation - minimum value setting and to deviations as a result of temperature, related to a difference of 10 K.

Test report P3MBP BlueLine



Prüfprotokoll

test certificate / protocole d'essai

Typ: P3MB	Auftrag: 801029754
<small>Type / type</small>	<small>order no / commande</small>
Nennmessbereich: 5000Bar	Prüfer: Rückert
<small>range / portée</small>	<small>examined / contrôleur</small>
IdentNr: 071610040	Datum: 15.2.2006
<small>serial no / n°p. ident</small>	<small>test date / date d'essai</small>

Prüfergebnisse:
test results / résultats d'essai

Eingangsgröße des Messbereichs [%] <small>input quantity / échelle d'essai</small>	Ausgangsgröße [mV/V] <small>output quantity / résultat</small>
0	0.0000
50	0.4970
100	0.9981
50	0.4973
0	0.0000

Die Prüfergebnisse über 3000 Bar sind extrapolierte Werte. Die maximale Prüfdruck beträgt 3000 Bar.
The test results exceeding 3000 Bar are extrapolated values. The maximum pressure for testing amounts to 3000 Bar.
Les résultats d'essai supérieurs à 3000 Bar sont des valeurs extrapolées. La pression maximale d'essai est de 3000 Bar.

Aus den Prüfergebnissen berechnete und sonstige messtechnische Eigenschaften:
characteristic data calculated from the measuring results and other values characteristic calculated by means of the results of the test

Kenwert C [mV/V] <small>sensitivity / sensibilité</small>	0.9981
Kennlinienabweichung, Anfangspunkteinstellung [%vC] <small>combined error / erreur combinée</small>	0.135
Relative Umkehrspanne [%vC] <small>relative hysteresis / hystérésis relatif</small>	0.028

Allgemeine Zusatzinformationen:
general information / renseignements complémentaires

Alle wesentlichen messtechnischen Eigenschaften des Aufnehmers sind durch Typprüfungen und laufende Produktionsaudits des Qualitätsmanagements abgesichert.
All other messtechnical characteristics of the transducer are verified by type testing and regular product audits of the quality department.
Tous les autres caractéristiques techniques du capteur sont garanties par le Service Qualité, au moyen d'essais et d'audits réguliers sur le produit.

Zertifiziert nach ISO 9001 und ISO 14001 (DQS-00001) Akkreditiertes DKD Kalibrierlaboratorium und EMV-Prüflaboratorium
ISO 9001 and ISO 14001 certified / Certification selon ISO 9001 et ISO 14001 Accredited DKD calibration laboratory and EMC testing laboratory
Laboratoire accrédité par le DKD en matière d'essais CEM **DKD-K-00101: DAT-P-00612**

Hottinger Baldwin Messtechnik GmbH Im Tiefen See 45 D-64293 Darmstadt 232 00 104395
Eumpale 10246 Version 4 18.04.2005 Mainz 02014

Information on the linearity of the individual transducer

Information on the sensitivity, characteristic curve deviation and rel. reversibility error of the individual transducer.

Specifications P3 Top Class BlueLine per DIN 16086

Type		P3 Top Class BlueLine		
Mechanical input quantities				
Pressure type		absolute pressure		
Principle of measurement		foil strain gage		
Measuring range, 0 bar...	bar	5000	10000	15000
Accuracy class ¹⁾		0.25	0.4	0.6
Output characteristics				
Nominal (rated) sensitivity	mV/V	1		
Sensitivity tolerance	%	< ± 0.2	< ± 0.4	< ± 0.8
Zero signal tolerance	%	< ± 1		
Creep upon unloading 15 min	%	< ± 0.03		
Effect of temperature on zero signal in the nominal (rated) excitation voltage range per 10K, rel. to nominal (rated) sensitivity				
in the nominal (rated) temperature range	%	± 0.05		
in the operating temperature range	%	± 0.10		
Effect of temperature on sensitivity in the nominal (rated) excitation voltage range per 10K, rel. to actual value				
in the nominal (rated) temperature range over 0 °C	%	± 0.05		
in the nominal (rated) temperature range below 0 °C	%	± 0.1		
in the operating temperature range	%	± 0.2		
Characteristic curve deviation (start setting)	%	0.25	0.4	0.6
Rel. interpolation error (max. deviation of a cubic interpolation function over the test series)	%	0.05	0.25	-
Long-term stability of zero signal and span (data per year)	%	0.2		
Repeatability per DIN 1319	%	< ± 0.05		

¹⁾ Accuracy class is not a DIN 16086 concept. The figure conforms to the maximum single deviation; that is the characteristic curve deviation - minimum value setting and to deviations as a result of temperature, related to a difference of 10 K.

Extended test report

Page 1

Test report P3 Top Class BlueLine

Page 2

Information on the linearity of the individual transducer

Information on the sensitivity, characteristic curve deviation and rel. reversibility error of the individual transducer.

Information on the max. interpolation error as a % and the coefficient of the cubic compensation function in the form $X = R \cdot Y^3 + S \cdot Y^2 + T \cdot Y$ of the individual transducer

Information on the temperature dependency of the individual transducer

Information on the temperature coefficient of the zero signal and on the temperature coefficient of the output span of the individual transducer.

The following data applies to P3MBP BlueLine and P3 Top Class BlueLine

Mechanical input quantities				
Measuring range, 0 bar...	bar	5000	10000	15000
Initial value	bar	0		
Operating range at reference temperature	%	120		110
Overload limit at reference temperature	%	120		110
Test pressure	%	195	150	100
Dynamic loading				
Permissible pressure	%	100		
Permissible oscillation width to achieve a typical 10,000,000 DIN 50100 load cycles	bar	3500	5000	6000
Dead volume	mm ³	615	150	100
with supplied packing ¹⁾	mm ³	200	-	-
Control volume	mm ³	approx. 1		
Output characteristics				
Fundamental resonance frequency	kHz	> 100		
Input resistance at reference temperature	Ω	350 ± 5		
Output resistance at reference temperature	Ω	350 ± 1.5		
Insulation resistance at 100 V AC	MΩ	5000		
Electrical strength	V	90		
Excitation voltage				
Reference excitation voltage	V	5		
Nominal (rated) excitation voltage	V	0.5 ... 7.5		
Operating range	V	0.5 ... 12		
Ambient conditions				
Permissible voltage between measuring circuit and transducer ground at reference temperature	V	50		
Materials for parts which come into contact with the environment (type-dependent)		1.4301; 1.4541; 1.4542; 1.6354 PU / chrome-plated and nickel-plated brass		
Reference temperature	°C	+23		
Nominal (rated) temperature range	°C	-10...+80		
Operating temperature range	°C	-40...+100		
Storage temperature range	°C	-40...+100		
Impact resistance (tested to DIN 40 046)				
Impact acceleration	m/s ²	1000		
Impact duration	ms	4		
Impact form		Half sine wave		
Acceleration sensitivity per 10 m/s ² for exciting frequencies of < 20% of natural frequency	%	< ± 0.001		
Mechanical specifications				
Pressure connection		M20 x 1.5 with 60° inner cone for use with 58° double cone		
Electrical connection		Lemo connector ERA.2E.310.SLL		
Cable		7 m ; free ends		
Bending radius of the connection cable, min.				
static	mm	35		
dynamic	mm	75		
Mounting position		any		
Weight without cable, approx.	g	200		
Degree of protection		IP67		

¹⁾ Packing is only used for the 5000 bar measuring range

Economical, standard versions available from stock:

Measuring range, 0 bar...	Pressure type	Product number
P3MBP BlueLine		
5,000 bar	absolute pressure	1-P3MBP/5,000 BAR
10,000 bar	absolute pressure	1-P3MBP/10,000 BAR
15,000 bar	absolute pressure	1-P3MBP/15,000 BAR
P3 Top Class BlueLine		
5,000 bar	absolute pressure	1-P3TCP/5,000 BAR
10,000 bar	absolute pressure	1-P3TCP/10,000 BAR
15,000 bar	absolute pressure	1-P3TCP/15,000 BAR

Pin assignment P3MBP BlueLine

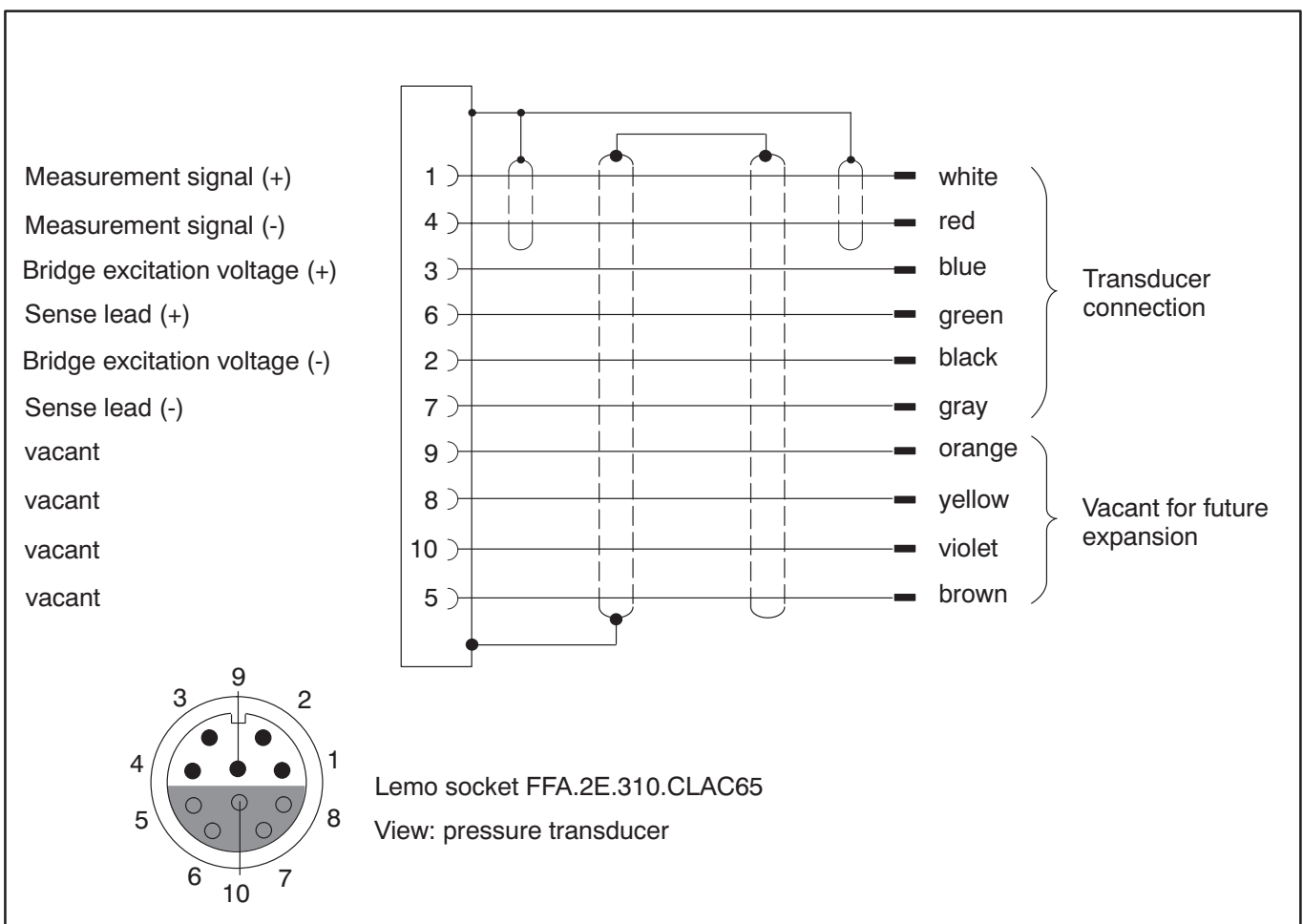

Pin assignment P3 Top Class BlueLine

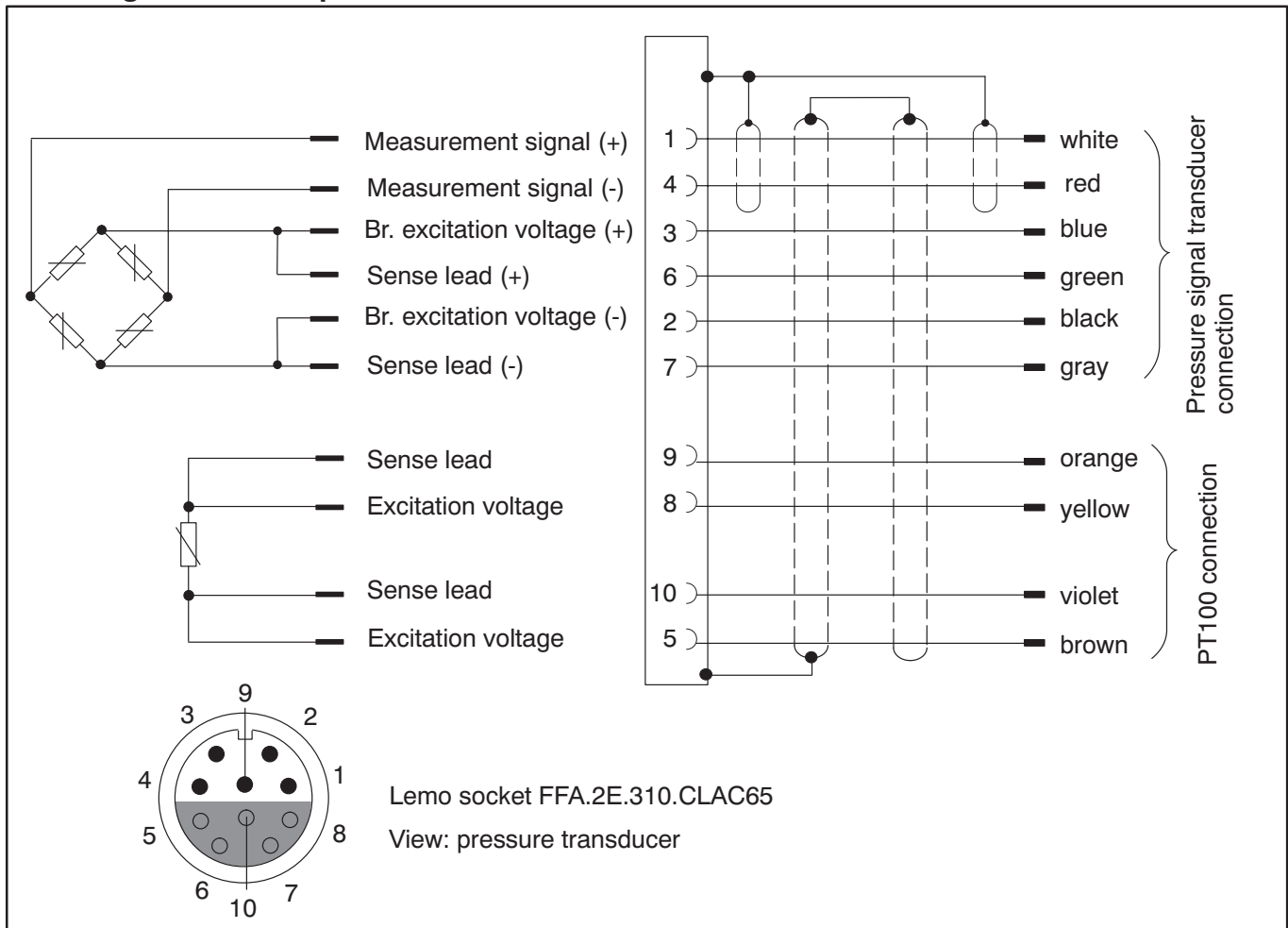

Accessories:

Included in scope of supply:

1 connection cable

PU cable sheath, resistant to oil, grease and solvents,
Order no.: 2-9268.0835, length 7 m, free ends

For 5,000 bar:

1 double-cone seal with filing elements, Order no.: 2-9289.5512, material 1.4305

For 10,000 bar and 15,000 bar:

1 double-cone seal, Order no.: 3-9219.0816, material 1.4542

Seal accessories:

5,000 bar

2-9278.0372 bag, conical seal P3MB/5000 bar

10,000 bar

2-9278.0373 bag, conical seal P3MB/10000 bar

15,000 bar

2-9278.0375 bag, conical seal P3MB/15000 bar

Pressure transducer mounting

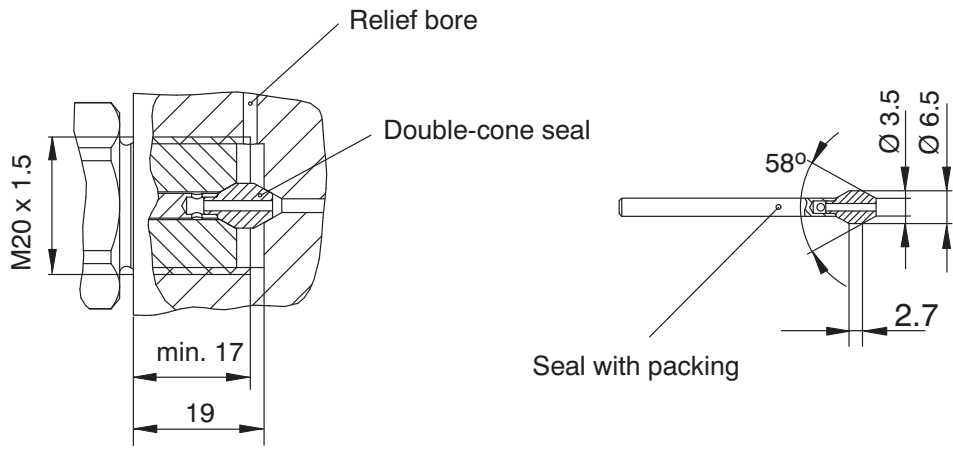

P3MBP 5000 bar

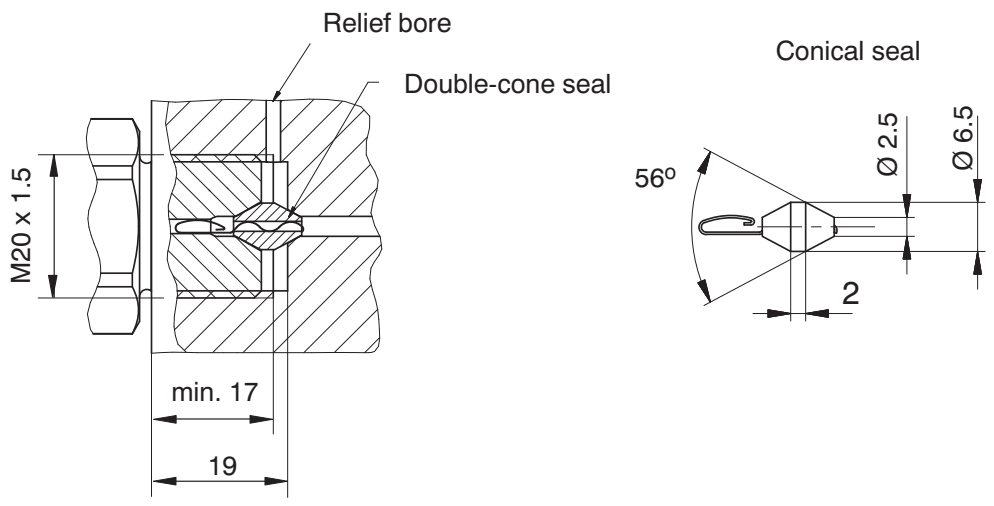

P3MBP 10000 bar and P3MBP 15000 bar

Regional Distributor



803, Riqqa Palace Building
Al-Maktum Ave.
P.O.Box 181802 Dubai, UAE
Tel: +9714 - 2270081
Fax: +9714 - 2239962
E-mail: rscso@eim.ae
www.rcs-co.com

Hottinger Baldwin Messtechnik GmbH

Im Tiefen See 45, D-64293 Darmstadt, Germany
Tel.: +49 6151 8030; Fax: +49 6151 803 9100
E-mail: support@hbm.com www.hbm.com



measurement with confidence