



P3 Top Class



P3MB version with fixed cable



P3MBP version with plug connection



TEDS: Transducer Electronic Data Sheet

P3

Absolute pressure transducer Nominal (rated) pressure 10 bar to 3000 bar

Special features

- For static and dynamic pressure variance, pressure peaks and pressure fluctuations
- Principle of measurement: foil strain gage
- OPTION: Explosion protection per ATEX

Top Class

- Better temperature response
- Individually documented values
- Improved accuracy class
- Closer sensitivity tolerance (suitable for parallel connection, for differential pressure measurement, for example)
- PT100 for temperature compensation in four-wire circuit

Dimensions (in mm) for P3 Top Class

Connection cable 2-9268.0835; 7 m long (included in scope of supply)

PUR approx. Ø6

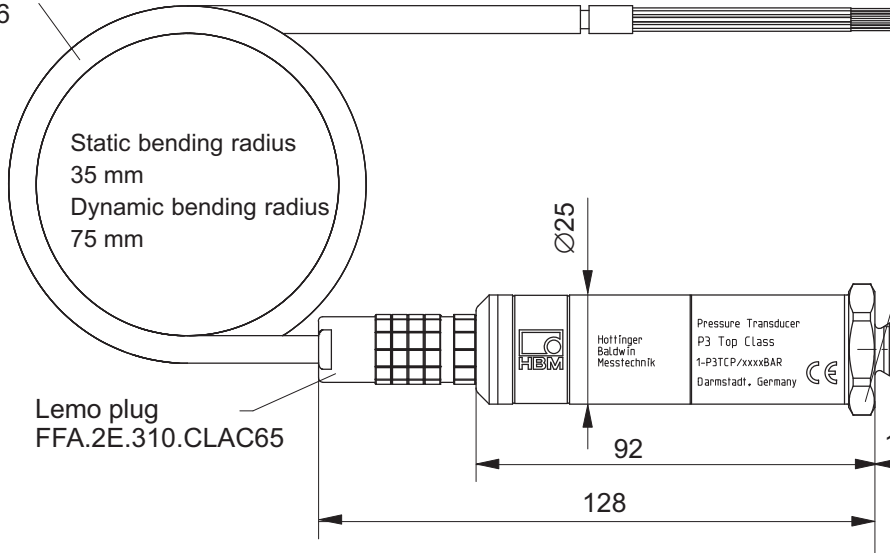

(M20 x 1.5 for 3000 bar measuring range)

Meas. range (bar)	Size a
10 - 200	4,8
500 - 2500	5,0

Specifications for P3, P3MB and P3MBP per DIN 16086

Type	P3, P3MB, P3MBP										
Mechanical input quantities											
Pressure type	absolute pressure										
Principle of measurement	foil strain gage										
Measuring range, 0 bar...	bar	10	20	50	100	200	500	1000	2000	3000	
Accuracy class		0.2	0.15	0.2	0.15		0.1		0.2		
Output characteristics											
Nominal (rated) sensitivity	mV/V	2								1.5	
Sensitivity tolerance	%	0.25	0.2			0.15					
Effect of temperature on zero signal in the nominal (rated) excitation voltage range per 10 K, rel. to nominal (rated) sensitivity											
	in the nominal (rated) temperature range	%									± 0.1
	in the operating temperature range	%									± 0.15
Effect of temperature on sensitivity in the nominal (rated) excitation voltage range per 10 K, rel. to actual value											
	in the nominal (rated) temperature range	%									± 0.1
	in the operating temperature range	%									± 0.2
Characteristic curve deviation (start setting)	%	± 0.20	± 0.15	± 0.2	± 0.15		± 0.10		± 0.2		
Repeatability per DIN 1319	%	± 0.05									

* Accuracy class is not a concept...

Test report P3MB, P3MBP

Information on the linearity of the individual transducer

Information on the sensitivity, characteristic curve deviation and rel. reversibility error of the individual transducer.



Prüfprotokoll

test certificate / protocole d'essai

Typ: P3	Auftrag: 801021987
Typ-Bezeichnung: P3	Art der Kommissionierung: Standard
Nennmessbereich: 500Bar	Prüfer: Schmitt
Ident-Nr.: 110210002	Datum: 15.02.2007
Ident-Nr. des Herst.: 110210002	Herstellungsdatum: 15.02.2007

Prüfergebnisse:
test results / résultats d'essai

Eingangsgröße des Messbereichs [%]	Ausgangsgröße [mV/V]
input quantity / échelle d'essai	output quantity / résultats
0	0.0000
50	0.9940
100	1.9962
50	0.9946
0	0.0000

Aus den Prüfergebnissen berechnete und sonstige messtechnische Eigenschaften:
 results calculated from the test results and other metrological and technical properties of the transducer and other metrological and technical properties of the transducer and other metrological and technical properties of the transducer.

Kennwert C [mV/V]	1.9962
Kennlinienabweichung, Anfangspunkteinrichtung [%vC]	0.135
Relative Umkehrspanne [%vC]	0.025

Allgemeine Zusatzinformationen:
 general information / renseignements généraux

Alle von uns messtechnischen Eigenschaften sind durch Typ-Übungen und laufende Überwachungen des Qualitätsmanagements abgesichert. Unsere Messgeräte sind über die Normale der Welt zu liefern und werden produziert unter der Qualitätssicherung. Toutes les caractéristiques techniques de nos produits sont garanties par nos services qualité, et nous nous assurons de la qualité de nos produits.

Zertifiziert nach ISO 9001 und ISO 14001 (DQS-9001) / ISO 9001 and ISO 14001 certified / Certifié selon ISO 9001 et ISO 14001 / Akkreditiertes DKG Kalibrierlabor für und EKV-Prüfzentrum / Accredited DKG Calibration Laboratory and EKV-Test Center / Laboratoire accrédité pour DKG et EKV-Prüfung / Laboratoire accrédité pour DKG et EKV-Prüfung / DKG-K-00161, DAT-P-00612

Hettinger Baldwin Messtechnik GmbH Im Tiefen See 45 D-64293 Darmstadt 069 46-10030 Fax: 069 46-10031 E-Mail: info@hbm.com

Specifications P3 Top Class per DIN 16086

Type		P3 Top Class										
Mechanical input quantities												
Pressure type		absolute pressure										
Principle of measurement		foil strain gage										
Measuring range, 0 bar...	bar	10	20	50	100	200	500	1000	2000	3000	2500	
Accuracy class ¹⁾		0.2	0.15	0.15	0.13			0.1				
Output characteristics												
Nominal (rated) sensitivity	mV/V	2 ± 0.15%									1.5 ± 0.15%	
Sensitivity tolerance	%	0.2	0.15				0.10					
Zero signal tolerance	%	± 0.1										
Creep upon unloading 15 min.	%	0.2	0.15			0.05	0.03					
Effect of temperature on zero signal in the nominal (rated) excitation voltage range per 10 K, rel. to nominal (rated) sensitivity												
in the nominal (rated) temperature range	%										± 0.05	
in the operating temperature range	%										± 0.10	
Effect of temperature on sensitivity in the nominal (rated) excitation voltage range per 10 K, rel. to actual value												
in the nominal (rated) temperature range over 0 °C	%										± 0.05	
in the nominal (rated) temperature range below 0 °C	%										± 0.1	
in the operating temperature range	%										± 0.2	
Characteristic curve deviation (start setting)..	%	0.20	0.15	0.15	0.13	0.10	0.10	0.10	0.10	0.10	0.10	
Rel. interpolation error (max. deviation) of a cubic interpolation function over the test series	%	0.10	0.08							0.05		
Long-term stability of zero signal and span (data per year)	%	0.4					0.20					
Repeatability per DIN 1319	%	± 0.05										

¹⁾ Accuracy class is not a DIN 16086 concept. The figure conforms to the maximum single deviation; that is the characteristic curve deviation – minimum value setting and to deviations as a result of temperature, related to a difference of 10 K.

Extended test report

Page 1

Test report P3 Top Class

Page 2

Information on the linearity of the individual transducer

Information on the sensitivity, characteristic curve deviation and rel. reversibility error of the individual transducer.

Information on the max. interpolation error as a % and the coefficient of the cubic compensation function in the form $X = R \cdot Y^3 + S \cdot Y^2 + T \cdot Y$ of the individual transducer

Information on the temperature dependency of the individual transducer

Information on the temperature coefficient of the zero signal and on the temperature coefficient of the output span of the individual transducer.

The following data applies to P3 and P3 Top Class

Mechanical input quantities											
Measuring range, 0 bar...	bar	10	20	50	100	200	500	1000	2000 2500	3000	
Initial value	bar	0									
Operating range at reference temperature	%	0...200					0...150				
Overload limit at reference temperature	%	250					200				
Test pressure	%	250					200			150	
Dynamic loading											
Permissible pressure	%	100									
Permissible oscillation width to achieve a typical 10,000,000 DIN 50100 load cycles	%	70									
Dead volume	mm ³	2500			2000			800		900	
Control volume	mm ³	9	7				1.5				
Output characteristics											
Fundamental resonance frequency	kHz	13	15	26	38	67	100				
Input resistance at reference temperature	Ω	350 ± 5									
Output resistance at reference temperature	Ω	350 ± 1.5									
Insulation resistance at 1000 V AC	MΩ	5000									
Electrical strength	V	90									
Excitation voltage											
Reference excitation voltage	V	5									
Nominal (rated) excitation voltage	V	0.5 ... 7.5									
Operating range	V	0.5 ... 12									
Ambient conditions											
Permissible voltage between measuring circuit and transducer ground at reference temperature	V	50									
Materials for parts which come into contact with the environment		1.4301; 1.4541; 1.4542; 1.6354 PU / chrome-plated and nickel-plated brass									
Reference temperature	°C	23									
Nominal (rated) temperature range	°C	-10...+80									
Limiting temperature range	°C	-40...+100									
Storage temperature range	°C	-40...+100									
Impact resistance (tested to DIN 40046)											
Impact acceleration	m/s ²	1000									
Impact duration	ms	4									
Impact form	-	Half sine wave									
Acceleration sensitivity per 10 m/s ² for exciting frequencies of 20% of the natural frequency	%	< ± 0.001									
Mechanical specifications											
Pressure connection		M12 x 1.5							M20 x 1.5		
Electrical connection		Lemo connector ERA.2E.310.SSL or a fixed 3 m cable or an HS6P device plug									
Bending radius of the connection cable, min.											
static	mm	35									
dynamic	mm	75									
Mounting position		any									
Weight without cable approx.	g	approx. 200									
Degree of protection (per DIN 40050, IEC 529)		IP67									

Economical, standard versions available from stock:

Measuring range, 0 bar to ...	Product number		
	P3 Top Class Lemo FFA 2E.310	P3MB cable connection 3 m cable, free ends	P3MBP with HS6P plug connection
10 bar	1-P3TCP/10BAR	1-P3MB/10BAR	1-P3MBP/10BAR
20 bar	1-P3TCP/20BAR	1-P3MB/20BAR	1-P3MBP/20BAR
50 bar	1-P3TCP/50BAR	1-P3MB/50BAR	1-P3MBP/50BAR
100 bar	1-P3TCP/100BAR	1-P3MB/100BAR	1-P3MBP/100BAR
200 bar	1-P3TCP/200BAR	1-P3MB/200BAR	1-P3MBP/200BAR
500 bar	1-P3TCP/500BAR	1-P3MB/500BAR	1-P3MBP/500BAR
1 000 bar	1-P3TCP/1000BAR	1-P3MB/1000BAR	1-P3MBP/1000BAR
2 000 bar	1-P3TCP/2000BAR	1-P3MB/2000BAR	1-P3MBP/2000BAR
2 500 bar	1-P3TCP/2500BAR	-	-
3 000 bar	1-P3TCP/3000BAR	1-P3MB/3000BAR	1-P3MBP/3000BAR

Pin assignment P3MB and P3MBP

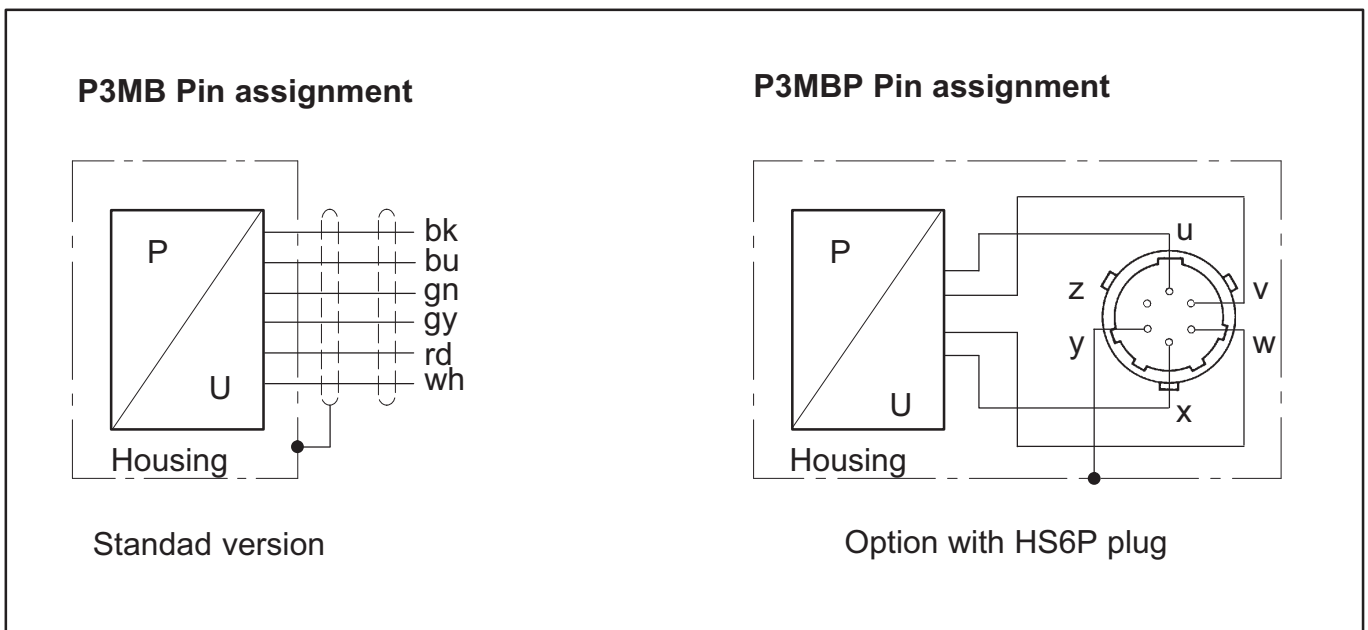

Pin assignment P3 Top Class

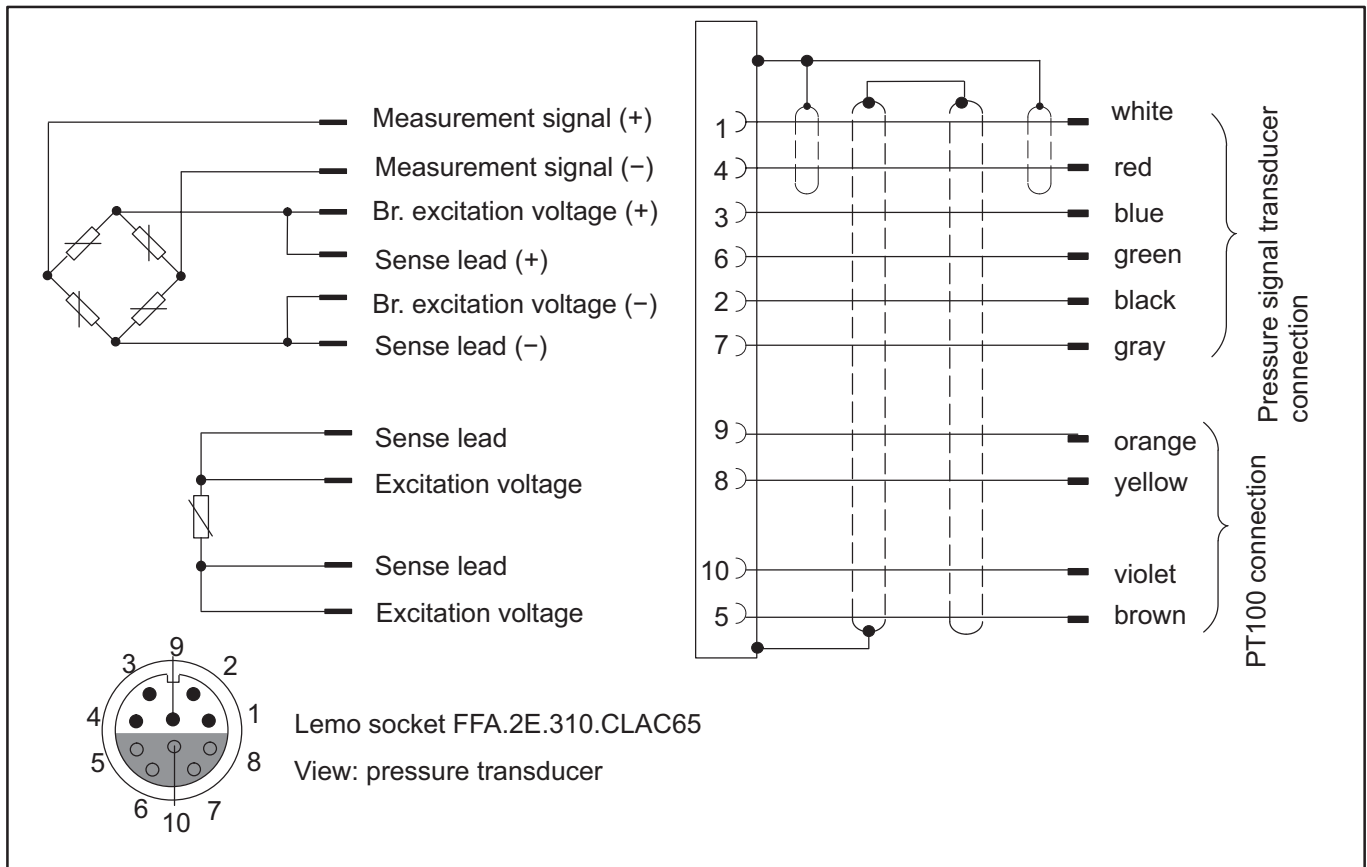

Dimensions for P3MB and P3MBP versions (P3 Top Class see first page) :

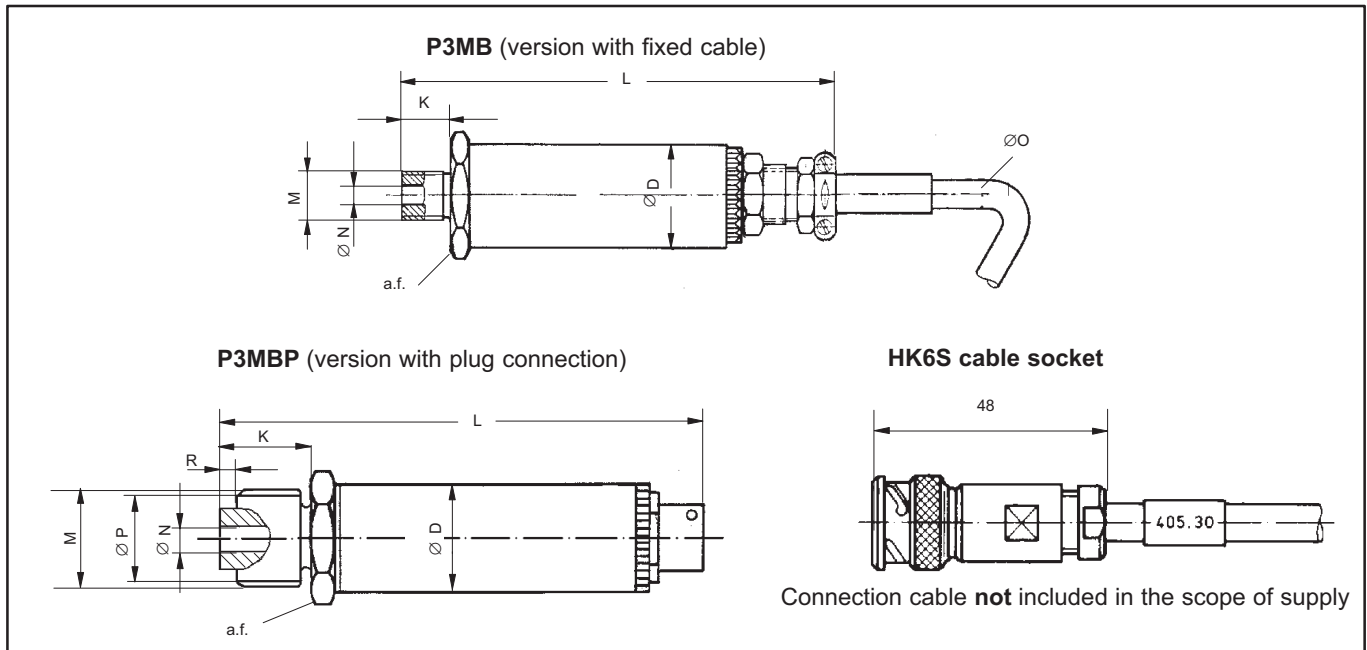

P3MB		D	K	L	M	N	O	P	a.f.	R
with cable connection	10 bar...2000 bar	25	12	112	M12 x 1.5	5	6.5	-	27	-
	3000 bar	25	20	129	M20 x 1.5	5	6.5	17.5	27	3
with plug connection	10 bar...2000 bar	25	12	97	M12 x 1.5	5	-	-	27	-
	3000 bar	25	20	105	M20 x 1.5	5	-	17.5	27	3

Accessories:

Included in scope of supply:

- 1 USIT ring U12.7 x 20 x 1.5 for P3MB.... / 10 bar to 500 bar
- 1 double-cone seal, 1.4305, for P3MB / 500 bar ... 3000 bar;
- Bag with 2 x conical seals made of material 1.4305
- 1 P3 Top Class connection cable

To be ordered separately:

Connecting branches
for measuring ranges to 500 bar
Material: stainless steel 1.4305

Type	D	K	L	M	N	O	P	R	S
P3M/500/M20	M12 x1.5	25	50	M20 x 1.5	4	20.2	5	5	3
P3M/500/R1/2	M12 x 1.5	20	50	G1/2	4	20.2	5	5	3

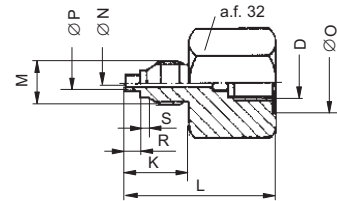

All dimensions in mm

Connection cable 1-KAB405.30A-3 (for variants with HS6P plug, to be ordered separately);with P3 Top Class (1-P3TCP...), the connection cable is included in the scope of supply

- HK6S cable socket, Order no. 3-3312.0095
- Cable plug for Greenline Order no. 1-MS3106PEMV
- 15-pin D-Sub plug, Order no. 2-9278.0321

Seal accessories:

- 10 to 200 bar 3-4218.0002 U seal/USIT ring U12.7 x 20 x 1.5, max. 500 bar
- 500 bar 3-4218.0002 U seal/USIT ring U12.7 x 20 x 1.5, max. 500 bar
- 2-9278.0376 bag, conical seal P3MB/500-3000 bar
- 1000 to 3000 bar 2-9278.0376 bag, conical seal P3MB/500-3000 bar

Options for P3MB:

Code	Option 1: Measuring range
010B	10 bar absolute pressure M12 x 1.5
020B	20 bar absolute pressure M12 x 1.5
050B	50 bar absolute pressure M12 x 1.5
100B	100 bar absolute pressure M12 x 1.5
200B	200 bar absolute pressure M12 x 1.5
500B	500 bar absolute pressure M12 x 1.5
01KB	1000 bar absolute pressure M12 x 1.5
02KB	2000 bar absolute pressure M12 x 1.5
03KB	3000 bar absolute pressure M12 x 1.5

Code	Option 2: Electrical connection
D	with cable, 3 m, D15 plug
A	with cable, 3 m, free ends, ATEX II 2 G EEx ib IICT4
F	with cable, to 20 m, D15 plug *)
M	with cable, 3 m, MS3106PEMV plug
N	with cable, to 20 m, MS3106PEMV plug *)
C	with HS6P plug, ATEX II 2 G EEx ib IIC T4 **)
B	with cable, to 20 m, free ends, ATEX II 2 G EEx ib IIC T4 *)
Y	with cable, to 20 m, free ends *)
*) Please specify cable length	
**) corresponds to PT06E-10-6S, from Bendix / UPT06J, from Cannon	

Product no. K-P3MB - -

Example order K-P3MB - 0 1 0 B - D

Pressure transducer mounting

P3 10 bar to 500 bar: USIT ring U12.7 x 20 x 1.5 (not shown)

P3 500–2500 bar

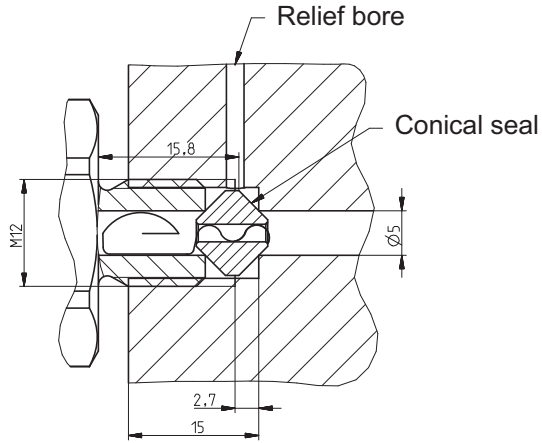

Conical seal
500–3000 bar

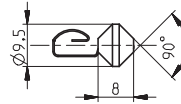

P3 3000 bar

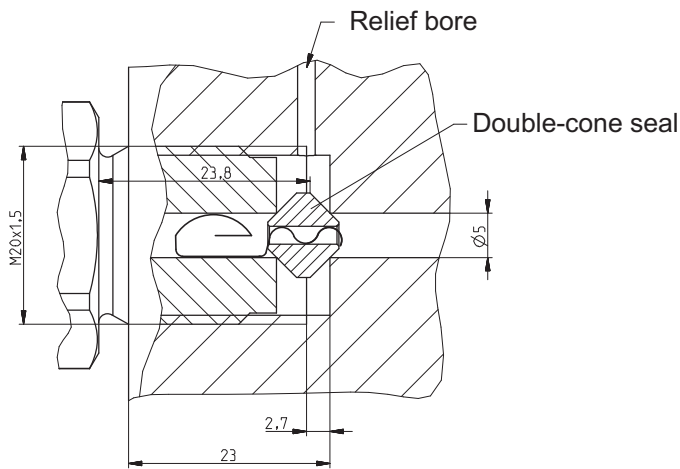

Double-cone seal
with retaining spring

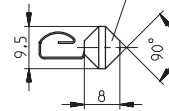

Regional Distributor



803, Riqqa Palace Building
Al-Maktum Ave.
P.O.Box 181802 Dubai, UAE
Tel: +9714 - 2270081
Fax: +9714 - 2239962
E-mail: rcsco@eim.ae
www.rcs-co.com

Hottinger Baldwin Messtechnik GmbH

Im Tiefen See 45, D-64293 Darmstadt, Germany
Tel.: +49 6151 8030; Fax: +49 6151 803 9100
E-mail: support@hbm.com www.hbm.com



measurement with confidence