

# PACEline

## CMC

Piezoelectric force measurement chain



### Special features

- Very compact force transducer combined with an industrial charge amplifier
- 2 calibrated measuring ranges of 100% and 20% F<sub>nom</sub>
- TEDS for each measuring range
- Nominal (rated) forces: 5, 20, 50, 70, 120 kN
- High stiffness
- Electrical isolation
- One-way fitting

### CFT dimensions

Nominal (rated) force: 5, 20 kN

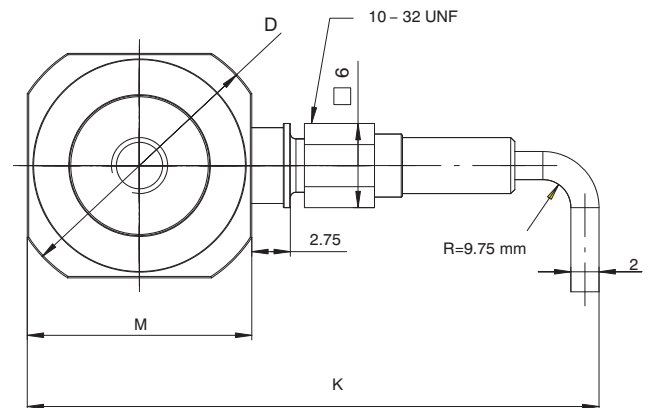
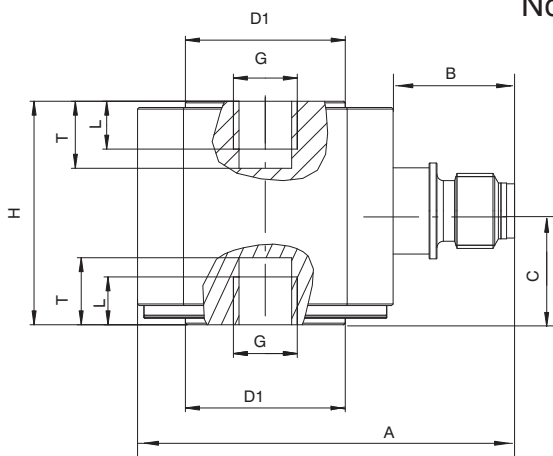

Type	D	D1	M	H	B	G	T	L	K	A	C
CFT / 5 kN	13	5	11	10	7.45	M2.5	3.15	2.25	36	18.45	5.05
CFT / 20 kN	19	10	16	14	7.45	M4	4.35	3	41	23.45	7.13

# Dimensions

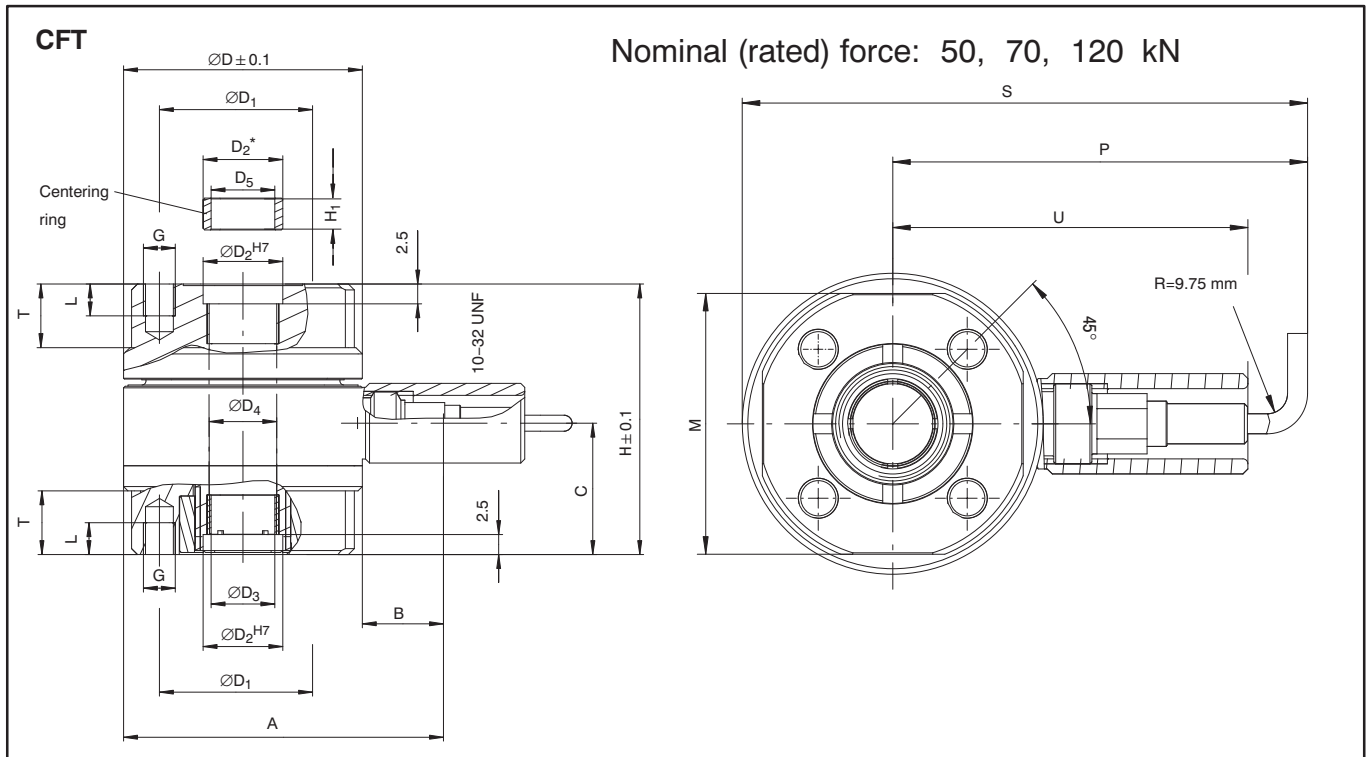

Type	D	D <sub>1</sub>	D <sub>2</sub>	D <sub>2</sub> *	D <sub>3</sub>	D <sub>4</sub>	D <sub>5</sub>	M	H	H <sub>1</sub>	B	G	T	L	A	C	S	P	U
CFT / 50 kN	30	21	10	10 <sub>f7</sub>	8	8.5	8 +0.02	26	34	4	10.05	M4	8	4	40.05	16.5	56.35	41.35	35.4
CFT / 70 kN	36	26	14	14 <sub>f7</sub>	11	12	11 +0.02	32	42	4	10.15	M5	9	5	46.15	21.5	62.35	44.35	38.4
CFT / 120 kN	54	40	21	21 <sub>f7</sub>	17	18.5	17 +0.02	48	60	4	10.15	M8	13	8	64.15	32	80.35	53.35	47.4

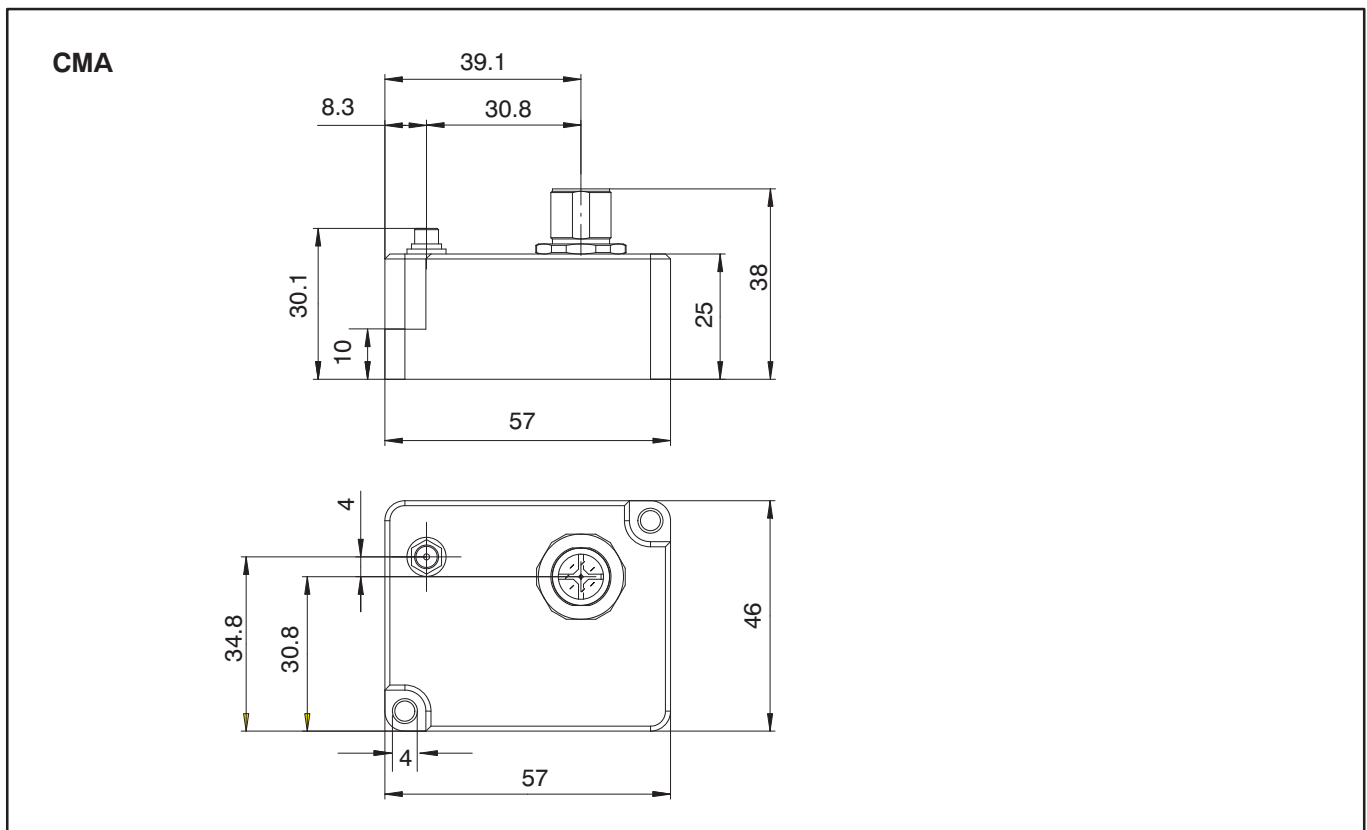

## Specifications (data per VDI/VDE 2638 standards)

Piezoelectric force measurement chain		CMC/...				
Nominal (rated) force	kN	5	20	50	70	120
Output span	V	± 10				
Output span tolerance	V	± 0.5				
Max. charge input	pC	39500	158300	210500	287000	482000
Calibrated measuring ranges	% F <sub>nom</sub>	100 20				
Relative reversibility error, 0.5 x F <sub>nom</sub>	%	< 1 (typ. 0.5)				
Relative linearity error	%	< ± 1 (typ. 0.5)				
Effect of temperature on output span / 10K	%	< 0.5				
Nominal temperature range	°C	0 ... 70				
Drift	pC/s	< 0.1				
Cut-off frequency	kHz	10 (-3dB) 5 (-1dB)				
Supply voltage	V	24 (18 ... 30)				
Power consumption	W	< 2				
Output resistance	Ω	< 10				
Permissible load resistance	kΩ	> 5				
Control inputs (electrically isolated)						
Reset/Measure step	pC	< ± 2				
Measure mode	V	MEASURE	0 ... +5 or open			
	V	RESET	12 ... 30			
Measurement range	V	RANGE 1	0 ... +5 or open			
	V	RANGE 2	12 ... 30			
Electrical connection		Force transducer 10 – 32 UNF Output/supply M12 x 1, 8–pin				
Degree of protection		IP 65				

Piezoelectric force transducer		CFT/...				
Nominal (rated) force	kN	5	20	50	70	120
Sensitivity	pC/N	-7,7	-7,7	-4,1	-4,1	-4,0
Perm. lateral force <sup>1)</sup>	% F <sub>nom</sub>	0.5			3.5	
Max. operational force	kN	5.5	22	60	84	144
Breaking force	kN	10	31	160	220	510
Natural frequency	kHz	40	36	54	46	31
Oscillation width	% F <sub>nom</sub>	100 for compressive force				
Operating temperature	°C	-40 ... +120				
Nominal (rated) displacement (± 15 %)	μm	11	18	30	30	31
Insulation resistance	Ω	> 10 <sup>13</sup>				
Degree of protection per DIN EN 60529		IP65				
Tightening torque for the connecting screws	N·m	0.5	1	2	4	21
Weight	g	8	22	137	240	720
Connection		10–32 UNF				

<sup>1)</sup> related to a point of contact on the force application surface

## Scope of supply

Order number	
1-CMC / 5 kN	CFT/ 5 kN piezoelectric force transducer , 3 m transducer connection cable CMA / 39 charge amplifier
1-CMC / 20 kN	CFT/ 20 kN piezoelectric force transducer , 3 m transducer connection cable CMA / 158 charge amplifier
1-CMC / 50 kN	CFT / 50 kN piezoelectric force transducer, 3 m transducer connection cable CMA / 210 charge amplifier
1-CMC / 70 kN	CFT / 70 kN piezoelectric force transducer, 3 m transducer connection cable CMA / 287 charge amplifier
1-CMC / 120 kN	CFT / 120 kN piezoelectric force transducer, 3 m transducer connection cable CMA / 482 kN charge amplifier

## Accessories:

1-KAB168-5	8-core cable to continuing electronics, 8-wire, M12x1 cable plug, 5 m long, free ends
1-KAB168-20	8-core cable to continuing electronics, 8-wire, M12x1 cable plug, 20 m long, free ends

Regional Distributor



803, Riqqa Palace Building  
Al-Maktum Ave.  
P.O.Box 181802 Dubai, UAE  
Tel: +9714 - 2270081  
Fax: +9714 - 2239962  
E-mail: rcsco@eim.ae  
www.rcs-co.com

Hottinger Baldwin Messtechnik GmbH

Im Tiefen See 45, D-64293 Darmstadt, Germany  
Tel.: +49 6151 8030; Fax: +49 6151 803 9100  
E-mail: support@hbm.com www.hbm.com



measurement with confidence